

---

---

**Petroleum and natural gas  
industries — External coatings for  
buried or submerged pipelines used  
in pipeline transportation systems —**

**Part 1:  
Polyolefin coatings (3-layer PE and  
3-layer PP)**

*Industries du pétrole et du gaz naturel — Revêtements externes  
des conduites enterrées ou immergées utilisées dans les systèmes de  
transport par conduites —*

*Partie 1: Revêtements à base de polyoléfines (PE tricouche et PP  
tricouche)*



Botop Steel



**COPYRIGHT PROTECTED DOCUMENT**

© ISO 2018

All rights reserved. Unless otherwise specified, or required in the context of its implementation, no part of this publication may be reproduced or utilized otherwise in any form or by any means, electronic or mechanical, including photocopying, or posting on the internet or an intranet, without prior written permission. Permission can be requested from either ISO at the address below or ISO's member body in the country of the requester.

ISO copyright office  
CP 401 • Ch. de Blandonnet 8  
CH-1214 Vernier, Geneva  
Phone: +41 22 749 01 11  
Fax: +41 22 749 09 47  
Email: [copyright@iso.org](mailto:copyright@iso.org)  
Website: [www.iso.org](http://www.iso.org)

Published in Switzerland

# Contents

	Page
<b>Foreword</b> .....	<b>v</b>
<b>Introduction</b> .....	<b>vi</b>
<b>1 Scope</b> .....	<b>1</b>
<b>2 Normative references</b> .....	<b>1</b>
<b>3 Terms and definitions</b> .....	<b>3</b>
<b>4 Conformance</b> .....	<b>6</b>
4.1 Rounding .....	6
4.2 Compliance with this document .....	6
<b>5 Symbols and abbreviated terms</b> .....	<b>6</b>
5.1 Symbols .....	6
5.2 Abbreviations .....	7
<b>6 Information supplied by the purchaser</b> .....	<b>7</b>
6.1 General information .....	7
6.2 Additional information .....	8
<b>7 Coating classification</b> .....	<b>9</b>
7.1 General .....	9
7.2 Coating classes .....	9
7.3 Coating thickness classes .....	9
<b>8 Qualification processes</b> .....	<b>10</b>
8.1 General — Qualification scheme .....	10
8.2 Application procedure specification .....	11
8.3 Pre-production trial (PPT) .....	12
8.4 Inspection and testing plan (ITP) .....	12
8.5 Procedure qualification trial (PQT) .....	13
<b>9 Coating material qualification</b> .....	<b>13</b>
9.1 Composition of the coating system .....	13
9.2 Qualification of the coating materials .....	14
9.2.1 General requirements .....	14
9.2.2 Epoxy material .....	14
9.2.3 Adhesive material .....	15
9.2.4 PE/PP top layer material .....	15
9.3 Batch certificate .....	17
9.4 Storage and handling of coating materials .....	18
<b>10 Coating system qualification</b> .....	<b>18</b>
<b>11 Application of the coating system</b> .....	<b>19</b>
11.1 General .....	19
11.2 Surface preparation .....	20
11.2.1 Initial preparation .....	20
11.2.2 Abrasive blast cleaning — Cleanliness and surface roughness .....	20
11.2.3 Surface dust contamination .....	20
11.2.4 Surface pre-treatment and salt contamination .....	21
11.3 Coating application .....	21
11.3.1 General .....	21
11.3.2 Epoxy application .....	21
11.3.3 Adhesive application .....	21
11.3.4 PE/PP application .....	22
11.3.5 Rough coat application .....	22
11.4 Cutback .....	22
<b>12 Inspection and testing</b> .....	<b>22</b>

12.1	General	22
12.2	Re-testing	25
<b>13</b>	<b>Coating repairs</b>	<b>25</b>
<b>14</b>	<b>Marking</b>	<b>25</b>
14.1	General	25
14.2	Required markings	26
<b>15</b>	<b>Handling and storage in the applicator's facilities</b>	<b>26</b>
15.1	Handling	26
15.2	Storage	26
<b>16</b>	<b>Test reports and certificate of compliance</b>	<b>26</b>
<b>Annex A</b>	<b>(normative) Inspection of thickness</b>	<b>27</b>
<b>Annex B</b>	<b>(normative) Holiday detection test</b>	<b>29</b>
<b>Annex C</b>	<b>(normative) Peel strength test</b>	<b>31</b>
<b>Annex D</b>	<b>(normative) Thermal analysis of epoxy and cured epoxy coating film with <math>T_g \leq 115^\circ\text{C}</math></b>	<b>34</b>
<b>Annex E</b>	<b>(normative) Impact test</b>	<b>39</b>
<b>Annex F</b>	<b>(normative) Indentation test</b>	<b>41</b>
<b>Annex G</b>	<b>(normative) UV ageing test and thermal ageing test</b>	<b>43</b>
<b>Annex H</b>	<b>(normative) Cathodic disbondment test</b>	<b>47</b>
<b>Annex I</b>	<b>(normative) Flexibility test</b>	<b>52</b>
<b>Annex J</b>	<b>(normative) Gel time of the epoxy powder</b>	<b>54</b>
<b>Annex K</b>	<b>(normative) Total volatile/moisture content of the epoxy powder — Mass loss</b>	<b>56</b>
<b>Annex L</b>	<b>(normative) Hot water immersion test</b>	<b>58</b>
<b>Annex M</b>	<b>(normative) Density of epoxy powder</b>	<b>60</b>
<b>Bibliography</b>		<b>62</b>

## Foreword

ISO (the International Organization for Standardization) is a worldwide federation of national standards bodies (ISO member bodies). The work of preparing International Standards is normally carried out through ISO technical committees. Each member body interested in a subject for which a technical committee has been established has the right to be represented on that committee. International organizations, governmental and non-governmental, in liaison with ISO, also take part in the work. ISO collaborates closely with the International Electrotechnical Commission (IEC) on all matters of electrotechnical standardization.

The procedures used to develop this document and those intended for its further maintenance are described in the ISO/IEC Directives, Part 1. In particular, the different approval criteria needed for the different types of ISO documents should be noted. This document was drafted in accordance with the editorial rules of the ISO/IEC Directives, Part 2 (see [www.iso.org/directives](http://www.iso.org/directives)).

Attention is drawn to the possibility that some of the elements of this document may be the subject of patent rights. ISO shall not be held responsible for identifying any or all such patent rights. Details of any patent rights identified during the development of the document will be in the Introduction and/or on the ISO list of patent declarations received (see [www.iso.org/patents](http://www.iso.org/patents)).

Any trade name used in this document is information given for the convenience of users and does not constitute an endorsement.

For an explanation of the voluntary nature of standards, the meaning of ISO specific terms and expressions related to conformity assessment, as well as information about ISO's adherence to the World Trade Organization (WTO) principles in the Technical Barriers to Trade (TBT) see [www.iso.org/iso/foreword.html](http://www.iso.org/iso/foreword.html).

This document was prepared by Technical Committee ISO/TC 67, *Materials, equipment and offshore structures for petroleum, petrochemical and natural gas industries*, Subcommittee SC 2, *Pipeline transportation systems*.

This second edition cancels and replaces the first edition (ISO 21809-1:2011), which has been technically revised.

The main changes compared to the previous edition are as follows:

- adoption of qualification processes ([Clause 8](#));
- added prescriptions for coating application on pipes made by corrosion resistant alloys (CRA) or lined/clad internally with a CRA;
- cathodic disbondment test conditions revised.

A list of all parts in the ISO 21809 series can be found on the ISO website.

Any feedback or questions on this document should be directed to the user's national standards body. A complete listing of these bodies can be found at [www.iso.org/members.html](http://www.iso.org/members.html).

## Introduction

It is necessary that users of this document be aware that further or differing requirements can be required for individual applications. This document is not intended to inhibit a vendor from offering, or the purchaser from accepting, alternative equipment or engineering solutions for the individual application. This can be particularly applicable where there is innovative or developing technology. Where an alternative is offered, it is the responsibility of the vendor to identify any variations from this document and provide details.

Botop Steel

# Petroleum and natural gas industries — External coatings for buried or submerged pipelines used in pipeline transportation systems —

## Part 1: Polyolefin coatings (3-layer PE and 3-layer PP)

### 1 Scope

This document specifies requirements for plant-applied external three-layer polyethylene and polypropylene based coatings for corrosion protection of welded and seamless steel pipes for pipeline transportation systems in the petroleum and natural gas industries in accordance with ISO 13623.

NOTE Pipes coated in accordance with this document are considered suitable for further protection by means of cathodic protection.

### 2 Normative references

The following documents are referred to in the text in such a way that some or all of their content constitutes requirements of this document. For dated references, only the edition cited applies. For undated references, the latest edition of the referenced document (including any amendments) applies.

ISO 179-1, *Plastics — Determination of Charpy impact properties — Part 1: Non-instrumented impact test*

ISO 179-2, *Plastics — Determination of Charpy impact properties — Part 2: Instrumented impact test*

ISO 306, *Plastics — Thermoplastic materials — Determination of Vicat softening temperature (VST)*

ISO 527-1, *Plastics — Determination of tensile properties — Part 1: General principles*

ISO 527-2, *Plastics — Determination of tensile properties — Part 2: Test conditions for moulding and extrusion plastics*

ISO 868, *Plastics and ebonite — Determination of indentation hardness by means of a durometer (Shore hardness)*

ISO 1133-1, *Plastics — Determination of the melt mass-flow rate (MFR) and melt volume-flow rate (MVR) of thermoplastics — Part 1: Standard method*

ISO 1183 (all parts), *Plastics — Methods for determining the density of non-cellular plastics*

ISO 2808, *Paints and varnishes — Determination of film thickness*

ISO 2811 (all parts), *Paint and varnishes — Determination of density*

ISO 3183, *Petroleum and natural gas industries — Steel pipe for pipeline transportation systems*

ISO 3251, *Paints, varnishes and plastics — Determination of non-volatile-matter content*

ISO 4892-2:2013, *Plastics — Methods of exposure to laboratory light sources — Part 2: Xenon-arc lamps*

ISO 6964, *Polyolefin pipes and fittings — Determination of carbon black content by calcination and pyrolysis — Test method and basic specification*

## ISO 21809-1:2018(E)

ISO 8130-2, *Coating powders — Part 2: Determination of density by gas comparison pycnometer (referee method)*

ISO 8130-3, *Coating powders — Part 3: Determination of density by liquid displacement pycnometer*

ISO 8130-7, *Coating powders — Part 7: Determination of loss of mass on stoving*

ISO 8501-1:2007, *Preparation of steel substrates before application of paints and related products — Visual assessment of surface cleanliness — Part 1: Rust grades and preparation grades of uncoated steel substrates and of steel substrates after overall removal of previous coatings*

ISO 8502-3, *Preparation of steel substrates before application of paints and related products — Tests for the assessment of surface cleanliness — Part 3: Assessment of dust on steel surfaces prepared for painting (pressure-sensitive tape method)*

ISO 8502-6, *Preparation of steel substrates before application of paints and related products — Tests for the assessment of surface cleanliness — Part 6: Extraction of soluble contaminants for analysis — The Bresle method*

ISO 8502-9, *Preparation of steel substrates before application of paints and related products — Tests for the assessment of surface cleanliness — Part 9: Field method for the conductometric determination of water-soluble salts*

ISO 8503-4, *Preparation of steel substrates before application of paints and related products — Surface roughness characteristics of blast-cleaned steel substrates — Part 4: Method for the calibration of ISO surface profile comparators and for the determination of surface profile — Stylus instrument procedure*

ISO 8503-5, *Preparation of steel substrates before application of paints and related products — Surface roughness characteristics of blast-cleaned steel substrates — Part 5: Replica tape method for the determination of the surface profile*

ISO 10350-1, *Plastics — Acquisition and presentation of comparable single-point data — Part 1: Moulding materials*

ISO 10474:2013, *Steel and steel products — Inspection documents*

ISO 11124 (all parts), *Preparation of steel substrates before application of paints and related products — Specifications for metallic blast-cleaning abrasives*

ISO 11126 (all parts), *Preparation of steel substrates before application of paints and related products — Specifications for non-metallic blast-cleaning abrasives*

ISO 11357-2, *Plastics — Differential scanning calorimetry (DSC) — Part 2: Determination of glass transition temperature and glass transition step height*

ISO 11357-6, *Plastics — Differential scanning calorimetry (DSC) — Part 6: Determination of oxidation induction time (isothermal OIT) and oxidation induction temperature (dynamic OIT)*

ISO 15512, *Plastics — Determination of water content*

ISO 17855-2, *Plastics — Polyethylene (PE) moulding and extrusion materials — Part 2: Preparation of test specimens and determination of properties*

ISO 18553, *Method for the assessment of the degree of pigment or carbon black dispersion in polyolefin pipes, fittings and compounds*

ISO 19069-2, *Plastics — Polypropylene (PP) moulding and extrusion materials — Part 2: Preparation of test specimens and determination of properties*

ISO 21809-2, *Petroleum and natural gas industries — External coatings for buried or submerged pipelines used in pipeline transportation systems — Part 2: Single layer fusion-bonded epoxy coatings*



ISO 80000-1, *Quantities and units – Part 1: General*

EN 10204:2004, *Metallic materials — Types of inspection documents*

ASTM D792, *Standard Test Methods for Density and Specific Gravity (Relative Density) of Plastics by Displacement*

ASTM D1505, *Standard Test Method for Density of Plastics by the Density-Gradient Technique*

ASTM D1693, *Standard Test Method for Environmental Stress-Cracking of Ethylene Plastics*

ASTM D4940, *Standard Test Method for Conductimetric Analysis of Water Soluble Ionic Contamination of Blast Cleaning Abrasives*

SSPC-AB 1,<sup>1)</sup> *Mineral and Slag Abrasives*

SSPC-AB 2, *Cleanliness of Recycled Ferrous Metallic Abrasives*

SSPC-AB 3, *Ferrous Metallic Abrasive*

SSPC-SP 1, *Solvent Cleaning*

SSPC-Guide 15, *Field Methods for Extraction and Analysis of Soluble Salts on Steel and Other Nonporous Substrates*

### 3 Terms and definitions

For the purposes of this document, the following terms and definitions apply.

ISO and IEC maintain terminological databases for use in standardization at the following addresses:

- ISO Online browsing platform: available at <https://www.iso.org/obp>
- IEC Electropedia: available at <http://www.electropedia.org/>

#### 3.1

##### **adhesion**

bond between coating and substrate

#### 3.2

##### **applicator**

company that undertakes the coating application in accordance with the provisions of this document

Note 1 to entry: If the compounding of the top layer is done prior to or during the application process by the applicator, then the applicator is regarded as the manufacturer (see 3.16).

#### 3.3

##### **application procedure specification**

##### **APS**

document describing procedures, methods, equipment and tools used for coating application

#### 3.4

##### **batch**

quantity of material produced in a continuous manufacturing operation using raw materials of the same source and grade

#### 3.5

##### **batch certificate**

certificate of analysis issued by the manufacturer

---

1) Society for Protective Coating, 40 24th Street, 6th floor, Pittsburg; PA 15222-4656, USA.

**3.6**

**certificate of compliance**

document issued in accordance with ISO 10474 or EN 10204, stating compliance with the purchase order for coated pipes, but without mention of any test results, issued in accordance with the purchasing requirements

**3.7**

**coating material qualification**

qualification of the coating materials properties carried out by the manufacturer before the coating system qualification

**3.8**

**coating system qualification**

qualification of application method, applied coating system and subsequent inspection/testing of its properties, to confirm that the APS is adequate to produce a coating with the specified properties

Note 1 to entry: The coating system qualification is not project dependent.

**3.9**

**cutback**

length of pipe left uncoated at each end for joining purposes

**3.10**

**design temperature range**

temperature range, including maximum and minimum temperatures, likely to be reached during transport, storage, handling, installation and operation

Note 1 to entry: The design temperature range of the coating can be narrower than that specified for the steel pipe material and/or the pipeline system.

**3.11**

**dummy pipe**

pipe having the same outside diameter and wall thickness of the project pipes. Dummy pipes and coated dummy pipes shall be representative of the production and shall be coated in accordance with approved APS

**3.12**

**end user**

company (companies) that own(s) and/or operate(s) pipeline(s)

**3.13**

**holiday**

coating discontinuity that exhibits electrical conductivity when exposed to a specific voltage

**3.14**

**inspection certificate 3.1**

document in accordance with ISO 10474 or EN 10204 giving the results of the testing of coated pipes, supplied and signed by a representative of the applicator authorized to issue such documents

**3.15**

**inspection and testing plan**

**ITP**

document providing an overview of the sequence of inspections and tests, including appropriate resources and procedures

**3.16**

**manufacturer**

company responsible for the manufacture of coating material(s)

**3.17****manufacturer's specification**

document that specifies the characteristics, test requirements and application recommendations for the coating materials

**3.18****operating temperature**

temperature that can be endured by a pipeline (component) and/or pipeline system during operation, within the design temperature range

**3.19****peel strength**

force required for peeling the coating from the substrate

**3.20****pipe diameter length**

length along the pipe axis equal to the specified outside diameter of the pipe

**3.21****pipeline**

components of a pipeline system connected together to convey fluids between stations and/or plants, including pipe, pig traps, components, appurtenances, isolating valves, and sectionalizing valves

[SOURCE: ISO 13623:2017, 3.1.15, modified]

**3.22****pipeline system**

pipelines, stations, supervisory control and data acquisition system (SCADA), safety systems, corrosion protection systems, and any other equipment, facility or building used in the transportation of fluids

[SOURCE: ISO 13623:2017, 3.1.16]

**3.23****pre-production trial****PPT**

application of a coating and subsequent inspection/testing of its properties, to confirm that the APS is adequate to produce a coating with the specified properties, carried out in the coating plant immediately prior to start of production and to verify that the plant's equipment is adequate to consistently adhere to the APS requirements

**3.24****procedure qualification trial****PQT**

application of a coating and subsequent inspection/testing of its properties, to confirm that the APS is adequate to produce a coating with the specified properties, carried out in correlation to a specific project

**3.25****purchaser**

company responsible for providing the purchase order requirements

**3.26****start up**

coating application activities re-start in case of modification of production parameters or unplanned stoppage or production interruption exceeding 12 h

**3.27****test report**

document that provides the quantitative test results for tests conducted in accordance with the requirements of this document

### 3.28

#### **total coating thickness**

sum of all three layers, namely epoxy material, adhesive material and top layer, with the exclusion of rough coat, if applicable

## 4 Conformance

### 4.1 Rounding

Unless otherwise stated in this document, to determine conformance with the specified requirements, observed or calculated values shall be rounded to the nearest unit in the last right-hand place of figures used in expressing the limiting value, in accordance with ISO 80000-1.

NOTE For the purpose of this provision, the rounding method of ASTM E29 is equivalent to ISO 80000-1.

### 4.2 Compliance with this document

A quality system and an environmental management system should be applied to assist compliance with the requirements of this document.

NOTE ISO 9001 gives guidance on quality management systems and ISO 14001 gives guidance on the selection and use of an environmental management system.

The applicator shall be responsible for complying with all the applicable requirements of this document. The purchaser shall be allowed to make any investigations necessary to ensure compliance by the applicator and to reject any material and/or coating that does not comply.

## 5 Symbols and abbreviated terms

### 5.1 Symbols

$C$	percentage conversion of FBE coating
$d$	effective sample thickness, expressed in millimetres
$D$	outside diameter of the pipe, expressed in millimetres
$\varepsilon_b$	tensile strain at break, expressed in %
$\Delta\varepsilon_b$	difference in tensile strain at break between 2 tests, expressed in %
$\Delta H$	exothermic heat of reaction, expressed in Joules per gram
$M$	mass, expressed in kilograms or grams
$\Delta MFR$	difference in the MFR between two tests, expressed in %
$P_m$	mass of bare pipe per metre length, expressed in kilograms per metre
$dQ/dt$	differential heat flow, expressed in watts per square metre
$r$	mandrel radius, expressed in millimetres
$T_g$	glass transition temperature, expressed in degrees Celsius

$\Delta T_g$	difference in the glass transition temperature between two successive thermal analysis scans, expressed in degrees Celsius
$w_m$	mass fraction of moisture, expressed as a percentage
$\rho_p$	density of the epoxy powder, expressed in grams per cubic centimetre

## 5.2 Abbreviations

APS	application procedure specification
Cr	chromium
CRA	corrosion resistant alloy
DSC	differential scanning calorimetry
ESCR	environmental stress cracking resistance
FBE	fusion-bonded epoxy
HDPE	high-density polyethylene
IR	infrared
ITP	inspection and testing plan
LDPE	low-density polyethylene
MDPE	medium-density polyethylene
MFR	melt flow rate
N.A.	not applicable
NPS	nominal pipe size
PDL	pipe diameter length
PE	polyethylene
PP	polypropylene
PPT	pre-production trial
PQT	procedure qualification trial
SAW	submerged arc welding
UV	ultraviolet

## 6 Information supplied by the purchaser

### 6.1 General information

The purchase order shall include the following information:

- a) number of this document and year of publication (ISO 21809-1:2018);

- b) pipe quantity, outside diameter, minimum wall thickness, minimum, maximum and nominal length, grade of steel;
- c) bare pipe standard or specification designation, e.g. ISO 3183;
- d) design temperature range in accordance with [7.2](#);
- e) operating temperature;
- f) coating class and coating thickness class in accordance with [7.2](#) and [7.3](#);
- g) qualification scheme as defined in [8.1](#);
- h) minimum number of coated pipes to be used for PPT and PQT (if required);
- i) cutback configuration and finish (length, angle, visible epoxy, temporary protection, etc.) (see [11.4](#));
- j) type of certificate of compliance (see [16](#)).

## **6.2 Additional information**

The purchase order shall specify which of the following provisions apply for the specific item ordered:

- a) pipe tracking and traceability of pipes to coating materials;
- b) different requirements for coating materials out of classification systems in accordance with [7.2](#);
- c) repair procedure qualification requirements and permissible number and size of coating repairs, if different from the one defined in [Clause 13](#);
- d) marking of pipes (see [14](#));
- e) handling procedures (see [15.1](#));
- f) storage procedures (see [15.2](#));
- g) documentation and schedule for supply of documentation;
- h) purchaser approval of APS/ITP;
- i) inspection and testing plan and/or daily log;
- j) inspection of incoming pipes;
- k) pipe end protection;
- l) use of different test methods for soluble salt contamination measurements;
- m) minimum thickness of epoxy layer and/or total coating thickness required, if exceeding those in [Table 9](#) and [Table 2](#), respectively;
- n) use of dummy pipe for destructive tests;
- o) rough coat application (e.g. prior to concrete weight coating or special laying methods) and acceptance criteria (see [11.3.5](#));
- p) surface pre-treatment and method to evaluate its effectiveness (see [11.2.4](#));
- q) special requirements relative to supply of coating materials (e.g. FBE or liquid, manufacturer-specific products and certification);
- r) methods, frequency and acceptance criteria for inspection and testing differing from this document;
- s) PQT (see [8.1](#));

- t) coating and cutback preservation and protection against adverse ambient conditions during storage (e.g. UV protection, additional cutback preparation, end-caps) (see [15.2](#));
- u) identification of pipes to be used for PPT (see [8.3](#)).

If further installation processes (e.g. welding processes and field joint coating application) that envisage the heating of the coated pipe are needed, further testing (e.g. adhesion) may be considered by the purchaser in order to assess the compatibility of the line pipe coating against the application parameters of the chosen field joint coating and vice-versa.

## 7 Coating classification

### 7.1 General

The coating class shall be selected based on the design temperature range and expected field duty.

The coating thickness class shall be selected based on transport, handling, laying conditions and the expected operating and environmental conditions.

### 7.2 Coating classes

The coating shall be capable of withstanding the temperature range required, as shown in [Table 1](#). The coating class shall be specified in the purchase order.

**Table 1 — Coating classes and design temperature ranges**

Coating class	Top layer material	Design temperature ranges (°C)								
		-40°C	-20°C	0°C	+20°C	+40°C	+60°C	+80°C	+100°C	+120°C
A	LDPE									
B	MDPE HDPE									
C <sup>a</sup>	PP									

<sup>a</sup> Installation and transportation at temperatures below 0°C can cause mechanical damage.

Coating classes B or C can be selected because of higher mechanical properties for project or specific laying purposes rather than maximum operating temperatures listed in [Table 1](#).

The use of coating classes outside these guidelines is acceptable provided that the applied coating shall be tested against the requirements specified in [Table 7](#) for each relevant class (i.e. class B shall be tested against requirements for class B in [Table 7](#), class C shall be tested against requirements for class C in [Table 7](#)).

Different requirements for coating materials outside these classification systems shall be agreed upon by the applicator and purchaser.

Use of coating classes outside these guidelines shall be approved by the purchaser or end user.

### 7.3 Coating thickness classes

The coating thickness class shall be selected by the purchaser or end user based on installation and service conditions and pipe dimensions. The coating thickness class, as shown in [Table 2](#) as a function of coating class and pipe weight, shall be specified in the purchase order.

Table 2 — Minimum total coating thickness

$P_m$ kg/m	Total coating thickness								
	mm								
	Class A1	Class A2	Class A3	Class B1	Class B2	Class B3	Class C1	Class C2	Class C3
$P_m \leq 15$	1,8	2,1	2,6	1,3	1,8	2,3	1,3	1,7	2,1
$15 < P_m \leq 50$	2,0	2,4	3,0	1,5	2,1	2,7	1,5	1,9	2,4
$50 < P_m \leq 130$	2,4	2,8	3,5	1,8	2,5	3,1	1,8	2,3	2,8
$130 < P_m \leq 300$	2,6	3,2	3,9	2,2	2,8	3,5	2,2	2,5	3,2
$P_m > 300$	3,2	3,8	4,7	2,5	3,3	4,2	2,5	3,0	3,8

A 10 % total coating thickness reduction is allowed on welds seam for SAW welded pipes.

Use of thickness classes outside these guidelines shall be approved by the purchaser or end user.

Class 1 or lower thicknesses can be used only for lighter installation/laying conditions (e.g. sandy soils, prepared backfill with selected materials).

Class 2 thickness can be applied for standard conditions (e.g. clay soils, backfill made by native soil, not coarse materials).

Class 3 thickness or higher can be applied as a minimum for more severe environments and installation/laying conditions (e.g. offshore, rocky soils).

## 8 Qualification processes

### 8.1 General — Qualification scheme

The qualification process as per this document includes the following qualification steps.

- a) Coating material qualification, by the manufacturer (9.2).

Each coating material shall be qualified by the manufacturer in accordance with the requirements of Tables 3, 4 and 5. The manufacturer shall carry out and report the coating material qualification in accordance with the requirements of Table 3, 4 and 5 where applicable. The test report issued by the manufacturer may be also certified by a certification organization.

- b) Coating system qualification, by the applicator (Clause 10).

Each coating system shall be qualified by the applicator. Qualification shall be carried out separately for each coating application line. The applicator shall prepare an APS (see 8.2) and ITP (see 8.4) related to the qualification of the specific coating system.

The applicator shall carry out and report the coating qualification in accordance with the requirements of Table 7. The test report shall contain the results of the qualification tests as per Table 7 and technical data required in Tables 6, 8 and 9. The test report issued by the applicator may be also certified by a certification organization.

- c) Pre-production trial (8.3).

A specific ITP shall be prepared. See 8.4.

- d) Procedure qualification trial (8.5).

In case a PQT is requested, a specific ITP shall be prepared. See 8.4.

Steps a), b) and c) are mandatory. Step d) shall be specified by the purchaser [see 6.2, s)].



If specified by the purchaser, PQT shall be executed in accordance with 8.5.

Execution of all of the above can be carried out preferably as individual steps, or alternatively in conjunction with others as indicated in Figure 1.

Figure 1 provides qualification scheme combinations together with the identification of the Tables to be considered for each phase and tests to be carried out.









Qualification Scheme	Pictogram			Applicable Table and tests		
	Coating Material Qualification / Coating System Qualification	PQT	PPT	Coating Material Qualification / Coating System Qualification	PQT	PPT
	A/B	D	C			
I.				Tab. 3, 4, 5 / 7, 8 and 9	Tab. 8 and 9	Tab. 8 and 9
II.				Tab. 3, 4, 5 / 7, 8 and 9		Tab. 8 and 9
III.				Tab. 3, 4, 5 / 7, 8 and 9	Tab. 8 and 9	
IV.				Tab. 3, 4, 5 / 7, 8 and 9		
<p>Note 1 If agreed, test certificates not older than three years are considered acceptable to cover requested tests for Coating Material Qualification and Coating System Qualification test report.</p>						

Figure 1 — Qualification schemes

The qualification scheme shall be specified by the purchaser (6.1).

Selection of the qualification scheme has to be carefully evaluated with respect to the availability of project pipes for PQT and the time frame required for the long-term test results for the coating materials and/or coating system qualification.

Option IV is not applicable for offshore pipelines or when coating Class A3, B3, C3 are selected.

Different pipes, e.g. diameter or type of steel, can be used upon agreement, if adopted process parameters are those that will be used for the project pipes. This option shall be carefully evaluated since the use of dissimilar pipes can affect the reliability of the results.

PQT or PPT shall be repeated in case of modifications to the coating line, coating materials or application procedures.

## 8.2 Application procedure specification

Prior to the selected qualification process (including possible specified PQT) and start of coating production, the applicator shall prepare an APS, including:

- incoming inspection of pipes and pipe tracking;

## ISO 21809-1:2018(E)

- manufacturer's specification (data sheets) for coating materials, including any materials used for coating repairs;
- manufacturer's specification (data sheets) for abrasive blasting materials;
- certification, receipt, handling and storage of materials for coating and abrasive blasting;
- cleaning procedure for all application equipment;
- preparation of the steel surface including monitoring of environmental parameters, methods and tools for inspection, grinding of pipe surface defects and testing of surface preparation;
- coating application, including tools/equipment for control of process parameters essential for the quality of the coating;
- lay-out sketch and flow diagram for the coating plant;
- methods and tools/equipment for inspection and testing of the applied coating;
- repairs of coating defects and any associated inspection and testing;
- stripping of defective coating;
- preparation of coating cutback areas;
- marking and traceability;
- handling and storage of pipes;
- any special conditions for dispatch of coated pipes, including protection of pipe ends;
- documentation.

The APS shall cover all items associated with quality control as defined in this document and any agreed amendments. It shall be available to the purchaser on request at any time during production.

The APS, including any revisions, shall be approved by the purchaser prior to the start of qualification and production.

### 8.3 Pre-production trial (PPT)

A PPT shall be carried out immediately prior to start of production.

Requirements for the frequency of testing and inspection, methods and acceptance criteria are contained in [Tables 8](#) and [9](#).

All items in the APS, from surface preparation to preparation of pipe ends shall be performed and inspected/tested.

The specific process parameters shall be as per the approved APS or ITP.

The results from the PPT shall be documented in a report, including the process parameters used, the APS and the coating material certificates.

In cases of orders with different combinations (pipe outside diameter and wall thickness) and where PPT is not going to be carried out on every combination, pipes to be used at the PPT shall be defined by the purchaser [see [6.2, u](#)].

### 8.4 Inspection and testing plan (ITP)

The applicator shall prepare an ITP and a daily log to record quality control data.

An ITP shall be prepared for any requested qualification and production acceptance testing.

Inspection frequencies shall be as per [Tables 8](#) and [9](#).

The ITP contents shall reflect all the process items, the items to be inspected and tested as described by the APS and related frequencies.

As a minimum the following shall be recorded:

- description of the activities;
- coating system;
- inspection points for each of the activities;
- applicable reference documents;
- applicable check procedures and methods/instruments;
- acceptance criteria;
- frequency of the checks;
- remedial actions;
- persons required to be present at the inspections;
- reporting.

If specified, a daily log shall be used to record all inspection and testing data, process parameters and calibrations of equipment for quality control.

### 8.5 Procedure qualification trial (PQT)

If a PQT is specified, the APS shall be verified during execution of the PQT.

When a PQT is specified, a specific ITP shall be prepared and subjected to purchaser's approval.

Requirements for the frequency of testing and inspection, methods and acceptance criteria are contained in [Tables 8](#) and [9](#).

All items in the APS, from surface preparation to preparation of pipe ends, shall be performed and inspected/tested on the specified number of samples.

The specific process parameters shall be selected to be used during the PQT so that the suitability of the ranges and combinations specified in the APS can be verified (e.g. a maximum value for one parameter can be applied in combination with a minimum value for another, if deemed critical).

Process parameters shall be monitored and recorded. For each of them the set point and allowable variations, either in absolute values or percentages, shall be provided.

The results from the PQT shall be documented in a report, including the process parameters used, the APS and the coating material certificates. Any recommendations for revision of the APS that apply for production shall be highlighted in the report.

## 9 Coating material qualification

### 9.1 Composition of the coating system

The three layer coating system comprises:

- 1st layer: epoxy;
- 2nd layer: adhesive applied by extrusion and/or by powder spray;

— 3rd layer: PE/PP top layer applied by extrusion.

If required, a rough coat can be applied to increase slip resistance.

## 9.2 Qualification of the coating materials

### 9.2.1 General requirements

The manufacturer shall qualify and issue a report for each type of coating material in compliance with the requirements of this document. The qualification shall be repeated in case of changes in the material composition, changes in the production process which influence the material processing behaviour and change in production facility.

The test report shall contain the results of the qualification tests and the data required in [Table 6](#).

The manufacturer shall carry out and report the material qualification in accordance with the requirements of [Clause 8](#) and [Tables 3, 4](#) and [5](#). The test report shall contain the results of the qualification tests and the data required in [Table 6](#). Test reports shall have three-year validity.

The applicator receiving the manufacturer's test report shall verify that it meets the requirement of this document.

### 9.2.2 Epoxy material

The applicator shall use epoxy material that is in accordance with [Table 3](#).

**Table 3 — Requirements for the epoxy material**

Properties	Unit	Test method	Requirements	
			Class A and Class B	Class C
Liquid mono-component <sup>a</sup> or bi-component epoxy				
Density	g/cm <sup>3</sup>	ISO 2811 (all parts)	Within ±0,05 of the manufacturer's specified nominal value	
Solid content of base and hardener	% mass	ISO 3251	In accordance with manufacturer's specification	
Minimum glass transition temperature ( $T_{g2}$ ) (DSC analysis <sup>b</sup> )	°C	<a href="#">Annex D</a>	≥95,0 and within manufacturer's specification	At least 5 above maximum pipeline design temperature with a minimum of 95,0
Gel time at 205 °C ± 3 °C	s	Manufacturer's specification	Within the 20 % of the nominal values specified by the manufacturer	
Epoxy powder (FBE)				
Moisture content	% mass	<a href="#">Annex K</a>	≤0,6	
Minimum glass transition temperature ( $T_{g2}$ ) (DSC analysis <sup>b</sup> )	°C	<a href="#">Annex D</a>	≥95,0 and within manufacturer's specification	At least 5 °C above maximum pipeline design temperature with a minimum of 95,0
<sup>a</sup> Liquid mono-component is limited to Class A only. <sup>b</sup> Curing condition (procedure as per manufacturer's specification).				

Table 3 (continued)

Properties	Unit	Test method	Requirements	
			Class A and Class B	Class C
Particle size	%	ISO 21809-2	3,0 % retained on 150 µm sieve ≤0,2 % retained on 250 µm sieve and within the manufacturer's specification	
Gel time at 205 °C ± 3 °C	s	<a href="#">Annex J</a>	Within 20 % of the nominal value specified by the manufacturer	
Density	g/cm <sup>3</sup>	<a href="#">Annex M</a>	Within ±0,05 of the manufacturer's specified nominal value	
<sup>a</sup> Liquid mono-component is limited to Class A only. <sup>b</sup> Curing condition (procedure as per manufacturer's specification).				

### 9.2.3 Adhesive material

The applicator shall use adhesive material that is in accordance with [Table 4](#).

**Table 4 — Requirements for the adhesive material (copolymeric or grafted adhesive in pellet or powder form)**

Properties	Unit	Test method	Requirements		
			Class A	Class B	Class C
Strain at break at 23 °C ± 3 °C <sup>a</sup>	%	ISO 10350-1 ISO 527-2	≥600	≥600	≥400
Density	g/cm <sup>3</sup>	ISO 1183 (all parts)	Within manufacturer's specification		
MFR	g/10 min	ISO 1133-1	Within manufacturer's specification		
Stress at yield at 23 °C ± 3 °C <sup>a</sup>	MPa	ISO 10350-1 ISO 527-2	≥5	≥8	≥12
Charpy impact strength, notched at minimum class temperature	kJ/m <sup>2</sup>	ISO 179-1 or ISO 179-2	—	—	≥3
Vicat softening temperature A/50	°C	ISO 306	≥60	≥85	≥115
Water content	%	ISO 15512 pellet or powder ISO 8130-7 powder	≤0,05	≤0,05	≤0,05
<sup>a</sup> For testing speed refer to <a href="#">G.1.4.2</a> .					

### 9.2.4 PE/PP top layer material

The applicator shall use PE/PP material that is in accordance with [Table 5](#).

Table 5 — Minimum requirements for PE/PP top layer

Properties	Unit	Test method	Requirements		
			Class A	Class B	Class C
Density of black compound	g/cm <sup>3</sup>	ISO 1183 (all parts) or ASTM D792 or ASTM D1505	≥0,930	≥0,940	N.A.
Density of the base resin (not black compound)	g/cm <sup>3</sup>	ISO 1183 (all parts) or ASTM D792 or ASTM D1505	≥0,920	≥0,930	≥0,890
Carbon black content	%	ISO 6964	2 – 3	2 – 3	N.A.
Carbon black dispersion	—	ISO 18553	Max Grade 3	Max Grade 3	N.A.
MFR	g/10 min	ISO 1133-1	Within manufacturer's specification		
Strain at break at 23°C ± 3°C <sup>a</sup>	%	ISO 10350-1 ISO 527-2	≥600	≥600	≥400
Stress at yield at 23 °C ± 3 °C <sup>a</sup>	MPa	ISO 10350-1 ISO 527-2	≥10	≥15	≥20
Charpy impact strength, notched at minimum class temperature	kJ/m <sup>2</sup>	ISO 179-1 ISO 179-2	—	—	≥3
Vicat softening temperature A/50	°C	ISO 306	≥95	≥110	≥130
Water content	%	ISO 15512 pellet or powder ISO 8130-7 powder	≤0,05	≤0,05	≤0,05
Hardness Shore D	—	ISO 868	≥50	≥55	≥60
ESCR (50 °C, F50)	h	ASTM D1693	≥300 Cond. A, 10 % Igepal CO630	≥1 000 Cond. B, 10 % Igepal CO630 or if density of black compound >0,955 g/cm <sup>3</sup> ≥300 Cond. B, 100 % Igepal CO630	N.A.
Oxidation induction time (intercept in the tangent method)	min	ISO 11357-6	≥30 at 210 °C	≥30 at 210 °C	≥30 at 220 °C
UV resistance and thermal ageing (not black PE compound)	%	<a href="#">Annex G</a>	ΔMFR ≤ 35 or Δε <sub>b</sub> ≤ 50 %	ΔMFR ≤ 35 or Δε <sub>b</sub> ≤ 50 %	N.A.
UV resistance and thermal ageing	%	<a href="#">Annex G</a>	ΔMFR ≤ 35	ΔMFR ≤ 35	ΔMFR ≤ 35

<sup>a</sup> For testing speed refer to [G.1.4.2](#).

If the compounding is done during the application process, the applicator shall perform the qualification tests for the product in accordance with [Table 5](#). The batch certificate, produced in accordance with [Table 6](#), shall be issued.

The carbon black used in the production of black compound shall be P type.

NOTE The applicator sometimes performs compounding with additives against UV and thermal ageing or other purposes.

### 9.3 Batch certificate

**9.3.1** The applicator shall provide batch certificates supplied by the manufacturer of each material and shall contain the information given in [Table 6](#). The batch certificate shall state test methods and acceptance criteria (i.e. acceptable ranges or min/max value).

The applicator shall identify the materials and shall confirm that the certificates comply and relate to the specified materials.

**Table 6 — Batch certificate**

Content	Coating material			
	Liquid epoxy	FBE	Adhesive	PE/PP top coat
Identification of the manufacturer	x	x	x	x
Product identification	x	x	x	x
Batch identification	x	x	x	x
Date and place of manufacturing	x	x	x	x
Density	x	x	x	—
Density of the compound	—	—	—	x
Viscosity of base and hardener	x	—	—	—
Solid content of base and hardener	x	—	—	—
Melt flow rate	—	—	x	x
Gel time	x	x	—	—
Particle size	—	x	x <sup>a</sup>	—
Moisture/water content	—	x	x	x
carbon black content	—	—	—	Only PE <sup>a</sup>
carbon black dispersion	—	—	—	Only PE <sup>a</sup>
Thermal characteristic	x	x	—	—
Reactive site content (direct or indirect methods can be proposed by the manufacturer)	—	—	x	—
<sup>a</sup> If applicable.				

**9.3.2** The manufacturer's specification for epoxy materials shall include the following:

- trade name;
- generic type;
- mix ratio (if any);
- maximum thickness, expressed in millimetres or micrometres ([Annex A](#));
- general information about application window;
- maximum and minimum storage temperatures, expressed in degrees Celsius;
- shelf-life at storage temperature, expressed in months;
- physical properties, in accordance with [Table 3](#).

9.3.3 The manufacturer's specification for adhesive and PE/PP materials shall include the following:

- trade name;
- description of the adhesive (if applicable);
- colour;
- maximum and minimum storage temperatures, expressed in degrees Celsius;
- shelf-life at storage temperature, expressed in months;
- physical properties, in accordance with [Tables 4](#) and [5](#).

9.4 Storage and handling of coating materials

Storage and handling of coating materials shall be in accordance with the manufacturer's specification.

10 Coating system qualification

Each coating system shall be qualified by the applicator. Qualification shall be carried out separately for each coating application line and a specific APS and ITP shall be prepared by the applicator.

The applicator shall carry out and report the coating system qualification in accordance with the requirements of this document. The test report shall contain the results of the qualification tests and data required in [Tables 6, 7, 8](#) and [9](#). The applicator shall apply coating materials qualified in accordance with the requirements of [9.2](#).

Qualification shall be repeated in case of modifications to the coating line, coating materials or application procedures.

Table 7 — Properties of the applied coating

Properties	Unit	Test method	Class A	Class B	Class C
Continuity	—	<a href="#">Annex B</a>	Free of defects and discontinuities, delaminations, separations and holidays		
Impact strength at 23 °C ± 3 °C	J/mm	<a href="#">Annex E</a>	>5	>7	>10
Indentation	at 23 °C ± 3 °C	<a href="#">Annex F</a>	≤0,3	≤0,2	≤0,1
	at maximum design temperature		≤0,4	≤0,4	≤0,4
Strain at break of PE/PP at 23 °C ± 3 °C <sup>a</sup>	%	ISO 527-2	≥400	≥400	≥400

a For testing speed refer to [G.1.4.2](#).



Table 7 (continued)

Properties		Unit	Test method	Class A	Class B	Class C
Peel strength		N/mm	<a href="#">Annex C</a>	$\geq 10,0$ at $\geq 23$ °C  $\geq 2,0$ at $\geq 60$ °C  No disbonding between steel and epoxy  If a non-grafted adhesive is used the failure mode shall be cohesive	$\geq 18,0$ at $\geq 23$ °C  $\geq 5,0$ at $\geq 80$ °C  No disbonding between steel and epoxy	$\geq 25,0$ at $\geq 23$ °C  $\geq 6,0$ at $\geq 90$ °C or at maximum operating temperature if above 90 °C  No disbonding between steel and epoxy
$\Delta T_g$		°C	<a href="#">Annex D</a>	$-3,0$ °C $\leq \Delta T_g \leq +3,0$ °C		
Product stability during application of the PE/PP top layer process		%	ISO 1133-1	for Classes A and B $\Delta MFR \leq 20$ ; for Class C $\Delta MFR \leq 35$ (variation between virgin compounded granulate before application and coating after application of the same batch tested by the applicator)		
Cathodic disbondment	at 23 °C/28 d; -1,38 V	mm	<a href="#">Annex H</a>	$\leq 5,0$		
	at 65 °C/24 h; -3,38 V			$\leq 4,0$		
	Max Op. temp (max 90 °C) /28d; -1,38 V			$\leq 15,0$		
Flexibility		Degrees per pipe length diameter	<a href="#">Annex I</a>	No cracking at an angle of 2,0° per pipe diameter length		
Resistance to hot water immersion test		mm	<a href="#">Annex L</a>	Average $\leq 2,0$ and maximum $\leq 3,0$		
a For testing speed refer to <a href="#">G.1.4.2</a> .						

## 11 Application of the coating system

### 11.1 General

The applicator shall apply qualified coating systems in accordance with requirements of [Table 9](#).

Throughout all stages of the coating application process from handling, surface preparation, coating, quenching, inspection and storage; special attention shall be given to ensure that pipes manufactured from a solid CRA or lined/clad internally with a CRA do not come into direct contact with carbon steel or become contaminated with carbon steel residue.

## 11.2 Surface preparation

### 11.2.1 Initial preparation

All dirt, deleterious matter and contaminants, such as oil and grease, shall be removed from the pipe prior to coating. If necessary, the pipe shall be cleaned in accordance with the requirements of SSPC-SP 1.

All steel defects and irregularities (e.g. laminations, slivers, scratches) shall be removed in accordance with the APS. Grinding of steel defects shall not reduce the wall thickness below the specified minimum wall thickness of the pipe.

All pipes shall be dry prior to entering the abrasive blast cleaning unit(s). The pipe temperature shall be at least 3 °C above the dew point immediately prior to abrasive blast cleaning.

### 11.2.2 Abrasive blast cleaning — Cleanliness and surface roughness

The abrasives used in the coating plant shall be in accordance with the respective requirements of ISO 11124 (all parts) or ISO 11126 (all parts). Pipes made of corrosion resistant alloys such as duplex stainless steel and 13 % Cr shall be blast cleaned using stainless steel abrasives or an expendable abrasive such as aluminium oxide. For carbon steel pipes lined/clad internally with CRA, care shall be exercised to prevent contamination by carbon steel abrasives on the inside of the pipe.

NOTE If the pipe being coated is of a high-strength grade, e.g. X80, X100 or X120, harder abrasives can be required to provide the required cleanliness and surface profile.

The abrasives (including recycled materials) shall be maintained clean, dry and free from contaminants in accordance with SSPC-AB 1, SSPC-AB 2 and SSPC-AB 3 or ASTM D4940 so as not to contaminate the substrate.

The cleanliness achieved at entry to the application line shall be in accordance with the requirements of ISO 8501-1:2007, grade Sa 2½ minimum.

NOTE Similar requirements are specified by SSPC and NACE (see Bibliography) with the approximate correspondence given hereafter:

ISO 8501-1	NACE	SSPC-SP	Designation
Sa3	1	5	White metal blast cleaning
Sa2½	2	10	Near-white metal blast cleaning

The height of the surface profile attained shall be within 50 µm and 100 µm, as measured in accordance with the requirements of ISO 8503-4 (Stylus method) or ISO 8503-5 (Replica tape method). The Stylus method shall be used for verification. The Replica tape method may be used when a correlation is established with the Stylus (Profilometer) method with a cut-off length of 2,5 mm.

If grinding is required after final blast cleaning, the maximum allowable area of grinding shall be 10 cm<sup>2</sup> per metre of pipe length or 0,5 % of the pipe surface area, whichever is lower. If the grinding area required exceeds these limits, the pipe shall be reblasted or spot blasted on ground area. The maximum allowable area of spot blasting shall be less than 5 % of the pipe surface area.

Reclaimed abrasive blast materials shall not be used unless automatic reclaiming equipment is used. Blasting equipment that includes devices to recycle abrasives shall have equipment that ensures removal of dust, fines, corrosion products and other contaminants.

### 11.2.3 Surface dust contamination

The dust level shall be measured in accordance with the requirements of ISO 8502-3. The maximum dust quantity rating shall be 2 and the maximum dust size class shall be 2.

#### 11.2.4 Surface pre-treatment and salt contamination

If the applicator chooses a surface pre-treatment (e.g. deionized water, phosphoric acid and/or chromate pre-treatment), the pre-treatment process shall be agreed with the purchaser.

If surface pre-treatment is used for a PQT, it shall be used for production. Process parameters (e.g. pressures, concentration, temperatures, etc.) shall be verified and maintained stable along the whole production.

Testing for the presence of soluble salts on the pipe shall be undertaken in accordance with the requirements of ISO 8502-6 and ISO 8502-9. Alternatively, if allowed by the pipe temperature, a salt contamination portable instrument can be used, according to SSPC Guide 15. The maximum allowable level shall be 20 mg/m<sup>2</sup> after blasting. If levels above 20 mg/m<sup>2</sup> of soluble salts are measured, a surface pre-treatment cleaning process shall be agreed upon by the applicator and the purchaser.

### 11.3 Coating application

#### 11.3.1 General

The coating shall be applied in accordance with the APS. During the application of the coating components, the pre-heating temperature of the pipe shall be monitored and recorded using optical pyrometers and checked with contact thermometers. Temperature-measuring crayons may be used to measure temperature only if agreed upon prior to coating, and shall be validated for temperature control during qualification and production of the coating system.

In order to minimise waste of CRA lined production pipes due to sampling for destructive tests, designated test pipes with the same characteristics as the production pipes can be introduced into the coating line and subsequently removed for destructive tests.

Throughout production, the blasting line speed, pre-heating temperature and the coating line speed shall be monitored continuously and the data recorded as per [Table 8](#) unless otherwise agreed with the end user/purchaser. Speed values during production run shall be within a range of  $\pm 10$  % of the value used and verified during PPT or PQT if carried out. Variation of the recorded values versus the set pre-heating temperature shall be within a range  $\pm 5$  % along the pipe length with the exception of the cutback ([11.4](#)) lengths.

During production if the above parameters (i.e. blasting line speed, pre-heating temperature and the coating line speed) require modification from the PPT or PQT values a new PPT shall be performed.

Use of recycled coating material is not allowed with the exception listed below for FBE.

#### 11.3.2 Epoxy application

Following surface preparation, the surface being coated shall not be exposed for a length of time that can result in flash rust. Between end of surface preparation and start of preheating, under no circumstance shall the time be more than 4 h and the pipe temperature shall remain at least 3 °C above the dew point.

The pipe temperature prior to and during epoxy application shall be in accordance with the APS.

The thickness of the epoxy layer after curing shall be in accordance with [Table 9](#). The  $\Delta T_g$  shall be in accordance with [Table 7](#).

Use of recycled FBE powder is allowed to a maximum of 20 %. Recycled FBE is not allowed if powder adhesive is used.

#### 11.3.3 Adhesive application

The elapsed time between epoxy application and adhesive application shall be in accordance with the APS.

Adhesive layer shall be continuous. Under no circumstances can the top layer (9.2.4) be in contact with epoxy (9.2.2).

11.3.4 PE/PP application

The application of the PE/PP layer shall be in accordance with the APS.

The applied coating shall be cooled to a temperature that prevents handling damage during finishing and final inspection.

The total coating thickness shall be in accordance with Table 2.

11.3.5 Rough coat application

If a rough coat is applied, requirements for its acceptance shall be agreed upon.

Requirements shall be agreed [see 6.2 o)] and specified e.g. rough material consumption per standard surface and its distribution.

11.4 Cutback

The coating at the pipe ends shall be removed to expose a length of bare metal as specified in the purchase order [see 6.1, i)].

The polyolefin shall be bevelled to an angle not exceeding 30° measured in the direction of the pipe axis.

For pipes manufactured from solid CRA, all tools used to remove coating from the pipe ends shall be manufactured from a suitable material such as stainless steel in order to avoid contamination by carbon steel.

For carbon steel pipes lined/clad internally with CRA, care shall be exercised to prevent contamination by carbon steel residues on the inside of the pipe.

NOTE It is advisable that some millimetres of FBE protruding from the polyolefin bevel might increase the long-term storage performances. Proper length shall be managed by purchaser through 6.1. The cutback length shall be measured from the root face of the pipe to the beginning of the coating bevel.

12 Inspection and testing

12.1 General

Inspection and testing shall be carried out in accordance with the APS, and ITP, and meet the requirements of Tables 8 and 9.

Table 8 — Requirements for inspection of surface preparation and coating application

Properties	Unit	Test method	Requirements	Frequency Coating System Qualification/ PQT/PPT	Frequency production
Surface condition before blasting	—	Visual inspection	Free of contaminations	Each pipe	Each pipe
Environmental conditions	—	Calculation and direct measurement	As determined at time of measurement	Once	Every 4 h
Pipe temperature before blasting	°C	Thermal contact probe	Minimum 3 °C above the dew point	Once	Every 4 h

Table 8 (continued)

Properties	Unit	Test method	Requirements	Frequency Coating System Qualification/ PQT/PPT	Frequency production
Size, shape and properties of virgin abrasive	—	Certification respective requirements ISO 11124 (all parts) (metallic) ISO 11126 (all parts) (non-metallic)	Conformity to certificate and compliance with manufacturing/ working procedures	Once	Every batch
Water-soluble contamination of abrasives	µS/cm	ASTM D4940	Conductivity max. 150	Once	1/shift
Soluble salt content after blasting	mg/m <sup>2</sup>	ISO 8502-6 or ISO 8502-9 or SSPC Guide 15	Salt content (as NaCl) max. 20	Each pipe	1/shift
Roughness of blasted surface	µm	ISO 8503-4 or ISO 8503-5	50 to 100	5 pipes to be tested	Every 1 h
Blasting Line Speed	m/min	Stopwatch	Compliance to APS	Each pipe	1/shift
Visual inspection of blasted surface	—	ISO 8501-1	Grade Sa 2 ½ minimum	Each pipe	Each pipe
Presence of dust after dust removal	—	ISO 8502-3	Max. quantity rating 2 Max. dust size 2	5 pipes to be tested	Every 1 h
Visual inspection of pipe prior to introduction to coating line	—	Visual	No flash rust	Each pipe	Each pipe
Temperature of extruded adhesive and top coat	°C	Thermometer or other approved equipment	Compliance to APS	Once	Every 1 h
Pre-heating temperature before coating	°C	Pyrometer or other approved equipment	Compliance to APS	Each pipe	Each pipe
Coating Line Speed	m/min	Stopwatch	Compliance to APS	Each pipe	1/shift

**Table 9 — Minimum frequency and requirements for inspection and testing of applied coating**

Properties	Unit	Test method	Requirements	Frequency Coating System Qualification/ PQT	Frequency PPT	Frequency production
Epoxy thickness <sup>a</sup>	µm	ISO 2808	Liquid epoxy: minimum 50 FBE: minimum 125 Maximum 400	1st pipe	1st pipe	Once every two shifts and at every start up
Minimum adhesive thickness <sup>a</sup>	µm	ISO 2808	150 on pipe body	1st pipe	1st pipe	Once every two shifts and at every start up
Degree of cure	°C	<a href="#">Annex D</a>	<a href="#">Table 7</a>	5 pipes	5 pipes	1st production pipe and 2/ shift
Continuity	—	<a href="#">Annex B</a>	<a href="#">Table 7</a>	5 pipes	5 pipes	Each pipe
Total coating thickness	mm	<a href="#">Annex A</a>	<a href="#">Table 2</a>	5 pipes	5 pipes	Every 10 pipes
Impact strength	J/mm	<a href="#">Annex E</a>	<a href="#">Table 7</a>	1 pipe	1 pipe	Once per PE/ PP batch
Peel strength Each pipe shall be tested at 23 °C at both ends with an additional test at high temperature	N/mm	<a href="#">Annex C</a>	<a href="#">Table 7</a>	5 pipes	5 pipes	Every 4 h
Indentation	mm	<a href="#">Annex F</a>	<a href="#">Table 7</a>	Once	Once	Each PE/PP batch
Strain at break	%	ISO 527-2	<a href="#">Table 7</a>	Once	Once	Each PE/PP batch
Cathodic disbondment	mm	<a href="#">Annex H</a>	23 °C/28 d; -1,38 V	Once	—	—
Cathodic disbondment	mm	<a href="#">Annex H</a>	Max Op. temp (max 90 °C)/28 d; -1,38 V	Once	—	—
Cathodic disbondment	mm	<a href="#">Annex H</a>	65 °C/24 h; -3,38 V	Once	Once	1/day
Resistance to hot water immersion test	mm	<a href="#">Annex L</a>	<a href="#">Table 7</a>	Once	Once	—
Flexibility	Degrees per pipe length diameter	<a href="#">Annex I</a>	<a href="#">Table 7</a>	Once	—	—
Product stability during application	%	ISO 1133-1	<a href="#">Table 7</a>	Once	Once	1st pipe per shift

<sup>a</sup> For FBE and adhesive thickness, it is measured on part-coated pipes over the length of pipe partially coated.

Table 9 (continued)

Properties	Unit	Test method	Requirements	Frequency Coating System Qualification/ PQT	Frequency PPT	Frequency production
Cutback	mm	Measuring	Subclause <a href="#">11.4</a>	5 pipes	5 pipes	Recorded once per hour
Residual Magnetism after coating application	Gauss	Gaussmeter	As per ISO 3183	5 pipes	5 pipes	1/shift
Coating repairs	—	Visual/ <a href="#">Annex B</a>	No holidays	Once for validation	—	Each defect

<sup>a</sup> For FBE and adhesive thickness, it is measured on part-coated pipes over the length of pipe partially coated.

## 12.2 Re-testing

Pipes that fail to meet the requirements of [Table 8](#) shall not be coated until the cause has been identified and corrected. Pipes that have been coated since the last acceptable test shall be accepted if they meet the requirements of [Table 9](#).

Pipes that fail to meet the requirements of [Table 9](#) shall be re-tested for the parameter(s) found to be out of specification. If the re-test also fails to meet the requirements in [Table 9](#), two pipes in the coating sequence prior to the pipe that failed and two pipes in the sequence after that pipe shall be re-tested.

If the results of all re-tested pipes are satisfactory, the coating shall be considered acceptable on all pipes except the pipe that failed. If any of the re-tests also fail, the total production back to the last test passed shall be blocked and further testing shall be initiated by the applicator and agreed with the purchaser. In the case of confirmed failure, the coating shall be rejected.

## 13 Coating repairs

Defects in the finished coating caused by the application process, transportation, handling and storage in the coating plant or in the storage area, as well as those that have been subjected to destructive testing, shall be repaired.

The defect area shall not exceed 10 cm<sup>2</sup> and the total number of defects shall not exceed 1 defect per metre length of pipe, unless otherwise specified. If the size or number of defects exceeds these limits, the affected pipe shall be stripped and recoated in accordance with the APS.

Defects shall be repaired and inspected using materials and procedures in accordance with the APS and any PQT. Repair materials shall be compatible with the applied coating.

If it is required to strip a pipe, it shall be carried out in accordance with the APS.

For pipes manufactured from solid CRA, all tools used to strip the coating and remove residual coating from the pipe surface shall be manufactured from a suitable material such as stainless steel in order to avoid contamination by carbon steel.

## 14 Marking

### 14.1 General

Coated pipes shall be marked in accordance with the requirements of [14.2](#) and with any additional markings specified in the purchase order [[6.2](#), d)]. Additional markings, as desired by the applicator, shall be by agreement.

## 14.2 Required markings

Marking shall be carried out using a method such as stencil painting and/or printing to ensure legible and indelible identification and shall be in accordance with APS.

The marking shall contain the following data:

- applicator's name or code;
- marking required by the applicable pipe specification or standard;
- reference to this document (ISO 21809-1:2018);
- coating thickness class;
- specified total coating thickness from [7.3](#);
- maximum design temperature (for Class C only).

EXAMPLE      Applicator – ISO 3183:2012 OD XYZ mm wt XYZ mm L415 – ISO 21809-1:2018 Class B2 –2,5 mm.

## 15 Handling and storage in the applicator's facilities

### 15.1 Handling

Coated pipes shall be handled in a manner that avoids damage to the pipe, pipe ends and coating. If specified in the purchase order, the applicator shall submit details of the handling procedures [see [6.2, e](#)]; such procedures shall include loading requirements where the applicator is responsible for loading.

Pipes that are damaged during processing shall be repaired in accordance with the requirements of the applicable pipe specification or standard.

Coating that is damaged after the holiday inspection (see [Table 9](#)) shall be repaired in accordance with the requirements of [Clause 13](#).

### 15.2 Storage

If specified in the purchase order, the applicator shall submit storage and coating preservation details [see [6.2, f](#)) and [6.2, t](#))] and shall specify in the APS details of the facilities and the methods being used for yard storage. Suitability of maximum stacking height shall be demonstrated by means of proper engineering calculations.

Solid CRA pipes or pipes lined/clad internally with a CRA shall be stored in an area separated from carbon steel pipes and end caps fitted to protect the inner CRA surface from carbon steel contamination.

## 16 Test reports and certificate of compliance

Unless otherwise specified in the purchase order [see [6.1, j](#))], an Inspection Certificate of type [3.1](#) in accordance with ISO 10474:2013 (or type [3.1](#) in accordance with EN 10204:2004) shall be issued by the applicator, which provides the results from the inspection and testing of the coating materials and coated pipes in accordance with the requirements of this document and any other requirements specified in the purchase order. If, however, in the purchase order, the purchaser does waive the requirement for an inspection certificate, then the applicator should provide a certificate of compliance.



## Annex A (normative)

### Inspection of thickness

#### A.1 General

The test shall consist of measuring the thickness of the applied coating by means of a non-destructive process.

#### A.2 Equipment

**A.2.1** Magnetic, electromagnetic, eddy-current or ultrasonic thickness-measuring instrument, with  $\pm 10$  % reading accuracy.

The instrument shall be calibrated for the range of coating thickness to be measured.

The choice of test instrument used shall be appropriate for the pipe material, which can have different ferromagnetic properties to carbon steel.

#### A.3 Procedure

**A.3.1** At the start of each shift verify the instrument reading on a steel pipe surface using calibrated shims or plates that are  $\pm 20$  % of the thickness being measured and if necessary, be adjusted. Calibration shall be carried out at the same temperature as the samples being measured. The surface roughness and cleanliness of the steel pipe surface shall be representative of the production pipe.

NOTE When measuring thickness of more than 1 mm, the surface roughness of the pipe is not relevant.

**A.3.2** On each pipe to be tested, carry out a total of 12 single readings in accordance with ISO 2808. If any of these 12 readings is below the minimum coating thickness, carry out an additional four readings around this area. The average of the additional four readings and the initial reading shall be higher than the minimum thickness.

Take the measurements at points distributed along four equally spaced longitudinal lines at the pipe length with three equally circumferential lines on the middle of the pipe at a distance of at least 300 mm from the end of the coating.

For submerged arc welded pipes, four thickness measurements shall be taken on the weld area.

#### A.4 Results and test reports

The results shall consist of all individual measurements and the calculated arithmetic average of all measurements

The test reports shall include at least the following:

- identification of test specimens (pipe number);
- procedure used;
- instruments used;

- reference to this document;
- ambient temperature and pipe temperature;
- date of test;
- test results.

Botop Steel

## Annex B (normative)

### Holiday detection test

#### B.1 General

This test shall consist of detecting any holiday of the coating using a scanning electrode energized by a high voltage. Defects shall be detected by a spark occurring between the steel and the electrode at the defect accompanied by a sound and/or light signal.

#### B.2 Equipment

**B.2.1 High-voltage holiday detector**, fixed or adjustable, calibrated to within 10 % of the required voltage, equipped with a sound and/or light signal.

**B.2.2 Scanning electrode**, in the form of a metal brush, coil spring or conductive rubber. The electrode shall conform to the shape of the pipe to ensure full coverage.

**B.2.3 Conductors**, which are used to complete the circuit.

#### B.3 Procedure

**B.3.1** The test shall be performed only on a coating that is free from surface moisture.

**B.3.2** At the start of each shift, the instrument shall be verified by a certified voltmeter and adjusted if necessary.

**B.3.3** The instrument (holiday detector) shall be connected to the pipe, completing the circuit, and switched on.

**B.3.4** Set the voltage at  $25 \text{ kV} \pm 2,5 \text{ kV}$ .

**B.3.5** The entire coated surfaces shall be inspected and the scanning electrode shall be passed over the surface of the coating being inspected with a continuous movement. The rate of the relative movement of the electrode shall not be limited, but it shall be demonstrated that a defect of 1 mm in diameter can be detected.

#### B.4 Results and test reports

The results shall consist of recording the number of holidays detected. Each holiday shall be marked for repair.

The test reports shall include at least the following:

- identification of test specimens;
- procedure used;
- instruments used;

- reference to this document;
- date of test;
- test results.

Botop Steel

## Annex C (normative)

### Peel strength test

#### C.1 General

The test shall consist of measuring the force required for peeling the coating from the metal substrate of the pipe at a constant rate of pull.

#### C.2 Equipment

**C.2.1 Tensile testing machine**, capable of recording the peel force with a 5 % reading accuracy, that operates at a rate of pull of 10 mm/min, example as shown in [Figure C.1](#) for small diameters or in [Figure C.2](#) for large diameters.

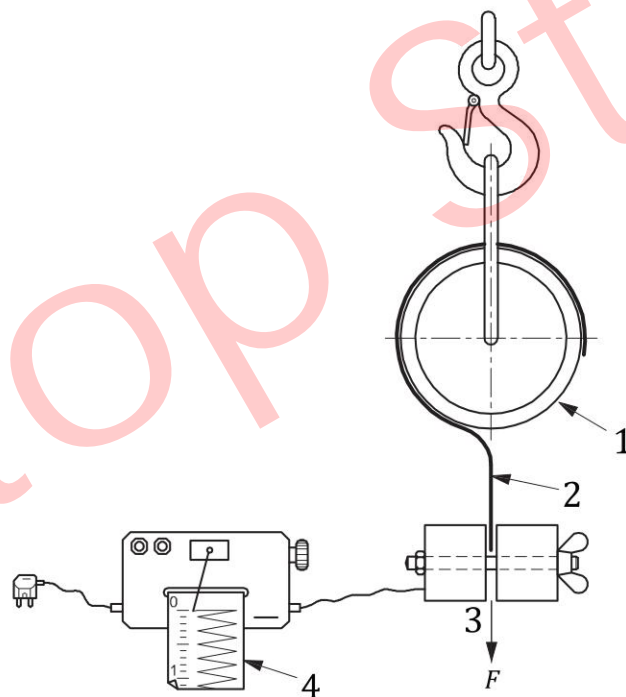

#### Key

- 1 pipe ring
- 2 coating strip
- 3 peel force,  $F$
- 4 registration unit

Figure C.1 — Peel strength test equipment for a small-diameter pipe

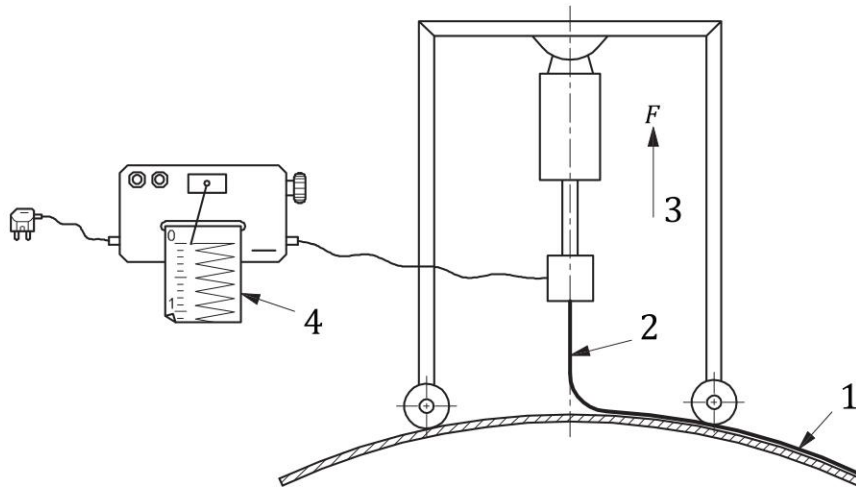

- Key**
- 1 coated pipe surface
  - 2 coating strip
  - 3 peel force,  $F$
  - 4 registration unit

**Figure C.2 — Peel strength test equipment for a large-diameter pipe**

**C.2.2 Cutting tool** (e.g. knife).

**C.3 Procedure**

**C.3.1 General**

**C.3.1.1** The coating thickness may be reduced to the minimum thickness of the coating class to facilitate peel testing.

**C.3.1.2** The peel test shall be performed at the temperatures specified in [Table 7](#).

**C.3.1.3** The temperature shall be measured by means of an adapted probe on the external surface of the pipe at the root of the peeled strip.

**C.3.1.4** The peel force shall be graphically recorded over 140 mm using a constant peeling speed of 10 mm/min.

**C.3.2 Small-diameter pipes**

**C.3.2.1** A pipe ring of 200 mm in length shall be cut from the pipe. Alternatively the test can be performed on the pipe end, directly on the pipe, without cutting the ring.

**C.3.2.2** A sample coating strip shall be cut in the circumferential direction of the pipe ring, measuring a minimum of 160 mm long and 20 mm to 50 mm wide.

**C.3.2.3** The pipe ring shall be free to rotate about its axis as shown in [Figure C.1](#).

**C.3.2.4** The cut end of the coating strip shall be secured to one of the gripping jaws of the testing machine and peeled perpendicular to the pipe axis.

### C.3.3 Large-diameter pipes

**C.3.3.1** The pipe shall be supported during the test to prevent movement.

**C.3.3.2** A sample coating strip shall be cut in the circumferential direction of the pipe, measuring a minimum of 160 mm long and 20 mm to 50 mm wide.

**C.3.3.3** The cut end of the coating strip shall be secured to one of the gripping jaws of the testing machine and peeled perpendicular to the pipe axis.

**C.3.3.4** A pipe ring or a cut sample can be used for measurement at high temperature instead of the pipe.

### C.4 Results and test reports

The results shall be calculated by dividing the peel force data for 140 mm of peeling into seven intervals of 20 mm, discarding the first and last intervals. The peel strength shall be calculated from the remaining data.

The average peel strength shall be the arithmetic mean over the 100 mm length. If this value is not automatically determined, the arithmetic mean may be estimated from the 20 mm bands across the 100 mm length.

The average peel strength shall meet the requirements of [Table 7](#) and no single recorded peeling value in the 100 mm length shall be 30 % below the specified value.

In case of break at 23 °C, the maximum peel force shall be recorded. The minimum requirements at 23 °C shall be fulfilled and the test shall then be carried out only at 90 °C (or at maximum operating temperature if higher than 90 °C).

The test reports shall include at least the following:

- identification of test specimens;
- procedure used;
- instruments used;
- reference to this document;
- temperature of test;
- date of test;
- test results.

## Annex D (normative)

### Thermal analysis of epoxy and cured epoxy coating film with $T_g \leq 115^\circ\text{C}$

#### D.1 General

Thermal analysis shall be used to characterize the uncured epoxy (powder, one-component liquid or two-component liquid) and the cured coating film.

Differential scanning calorimetry (DSC) shall be used. Reference can be made to ISO 11357-2 for a description of the general procedure and definitions. General handling and calibration shall be performed as in ISO 11357-2 unless stated otherwise in this document.

For FBE with a glass transition temperature above  $115^\circ\text{C}$ , testing shall be according to the manufacturer's recommendation.

#### D.2 Equipment

D.2.1 **Differential scanning calorimeter (DSC)**, with cooling accessory.

D.2.2 **Balance**, accurate to 0,1 mg.

D.2.3 **Sample-encapsulating press**.

D.2.4 **Aluminium pans**, with covers.

D.2.5 **Nitrogen gas supply**, dry, analytical grade.

#### D.3 Procedure and measurement for epoxy

##### D.3.1 Procedure

For two-component epoxy liquid, taking into consideration the supplier's recommendations, accurately and separately homogenize each component before use and mix them together in the exact mixing ratio; then continue to homogenize completely the mix of base and hardener for about 5 min. The minimum quantity to be mixed is 100 g to avoid mixing mistakes.

For one-component epoxy liquid, taking into consideration the supplier's recommendations, completely homogenize 100 g of the sample before use.

##### D.3.2 Measurement

Perform the following heating cycles, starting with run (a) as the conditioning run for powder epoxy only.

- Run (a): heat the sample from  $25^\circ\text{C} \pm 5^\circ\text{C}$  to  $70^\circ\text{C} \pm 5^\circ\text{C}$  at a rate of  $20^\circ\text{C}/\text{min}$ , then immediately cool the sample to  $25^\circ\text{C} \pm 5^\circ\text{C}$ .
- Run (b): heat the sample from  $25^\circ\text{C} \pm 5^\circ\text{C}$  to  $275^\circ\text{C} \pm 5^\circ\text{C}$  at a rate of  $20^\circ\text{C}/\text{min}$ , then immediately cool the sample to  $25^\circ\text{C} \pm 5^\circ\text{C}$ . Hold for 3 min at  $25^\circ\text{C} \pm 5^\circ\text{C}$ .



- Run (c): heat the sample from  $25\text{ °C} \pm 5\text{ °C}$  to  $T_g + 40\text{ °C}$  (typically  $150\text{ °C}$ ) at a rate of  $20\text{ °C/min}$ , then immediately cool the sample to  $25\text{ °C} \pm 5\text{ °C}$ .

For certain epoxies, different heating cycles can be required according to the instructions of the epoxy manufacturer.

## D.4 Evaluation of results

### D.4.1 Glass transition temperature

The glass transition temperature,  $T_g$ , is calculated at the point of inflection intersection (see [Figure D.1](#)).

By evaluating run (b), the  $T_g$  of the uncured powder obtained is equal to  $T_{g1}$ . By evaluating run (c), the  $T_g$  of the cured material (powder and liquid) obtained is equal to  $T_{g2}$ .

### D.4.2 Heat of reaction of the epoxy

The exothermic heat of reaction,  $\Delta H$ , is obtained by integrating the exothermic peak of the DSC scan.

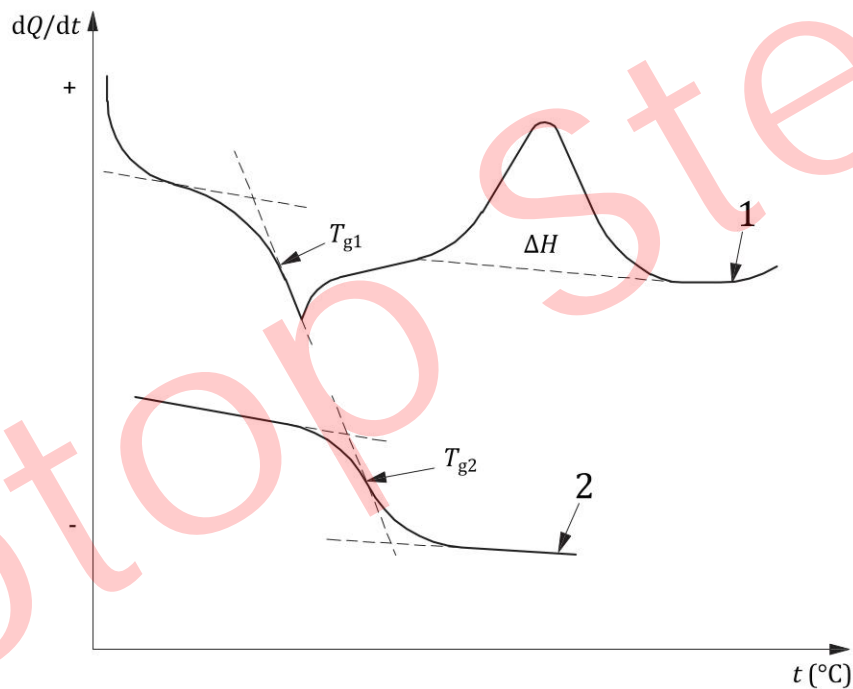

#### Key

- 1 run (b)
- 2 run (c)

Figure D.1 — Examples of thermal scans on epoxy powder

## D.5 Procedures and measurement for coating sample

### D.5.1 Sample preparation

#### D.5.1.1 Two-component epoxy liquid

Accurately and separately homogenize each component before use in accordance with the instructions of the manufacturer.

Mix them together in the exact ratio and completely homogenize the mix of base and hardener for about 5 min.

Apply the product at the thickness of 500  $\mu\text{m}$  on an aluminium panel that has been completely degreased. The thickness of the panel is about 1 mm.

Let the film cure for at least 2 h at ambient temperature. Put the panel in a ventilated oven for 15 min at 170 °C, then take it out and let it cool at ambient temperature.

After about 2 h, bend the aluminium panel and take off one or more scales of the film in order to get the necessary mass of material to put in the test capsule.

As an alternative, a representative sample of cured film may be taken directly from the pipe.

#### **D.5.1.2 One-component epoxy liquid**

Homogenize the sample before use in accordance with the instructions of the manufacturer.

Apply the product at the thickness of 500  $\mu\text{m}$  on an aluminium panel that has been completely degreased. The thickness of the panel is about 1 mm.

Let the film cure for at least 2 h at ambient temperature. Put the panel in a ventilated oven for 15 min at 170 °C, then take it out and let it cool at ambient temperature.

After about 2 h, bend the aluminium panel and take off one or more scales of the film in order to get the necessary mass of material to put in the test capsule.

As an alternative, a representative sample of cured film may be taken directly from the pipe.

#### **D.5.1.3 Epoxy powder**

A representative sample of the cured film shall be taken directly from the pipe using a scraper.

Weigh out 10 mg  $\pm$  3 mg to an accuracy of 0,1 mg. The pan is sealed with the cover. Determine the final mass after sealing.

Place the sample and the reference sample in the DSC cell and purge with dry, nitrogen gas.

Samples taken from pipes that have been stored or buried shall be dried before testing.

### **D.5.2 Measurement**

The following heating cycles shall be performed, starting with run (a) as the conditioning run for the powder samples only.

Liquid epoxy samples shall start with run (b).

- Run (a): heat the sample from 25 °C  $\pm$  5 °C to 110 °C  $\pm$  5 °C at a rate of 20 °C/min and hold for 1,5 min, then cool the sample to 25 °C  $\pm$  5 °C.
- Run (b): heat the sample from 25 °C  $\pm$  5 °C to 275 °C  $\pm$  5 °C at a rate of 20 °C/min, then cool the sample to 25 °C  $\pm$  5 °C. Hold for 3 min at 25 °C  $\pm$  5 °C. If minor decomposition is observed, the test shall be repeated [Run (a) and (b)] using a new sample with the end point temperature selected just before the onset of decomposition.
- Run (c): heat the sample from 25 °C  $\pm$  5 °C to  $T_g + 40$  °C (typically 150 °C) at a rate of 20 °C/min, then cool the sample to 25 °C  $\pm$  5 °C.

For certain epoxies, different heating cycles can be necessary according to the instructions of the epoxy manufacturer.

Samples taken from pipes that have been stored or buried shall be dried before testing.

### D.5.3 Evaluation of results

#### D.5.3.1 Glass transition temperature

The glass transition temperature,  $T_g$ , shall be calculated in the same way for the epoxy for run (b) and run (c) in [Figure D.2](#) where  $T_{g3}$  is  $T_g$  of run (b) in [D.5.2](#) and  $T_{g4}$  is  $T_g$  of run (c) in [D.5.2](#), all expressed in degrees Celsius.

For coatings, determine  $\Delta T_g$ , the change in  $T_g$  value, using [Formula \(D.1\)](#) and the  $T_g$  values defined in paragraph 1.

$$\Delta T_g = T_{g4} - T_{g3} \quad (\text{D.1})$$

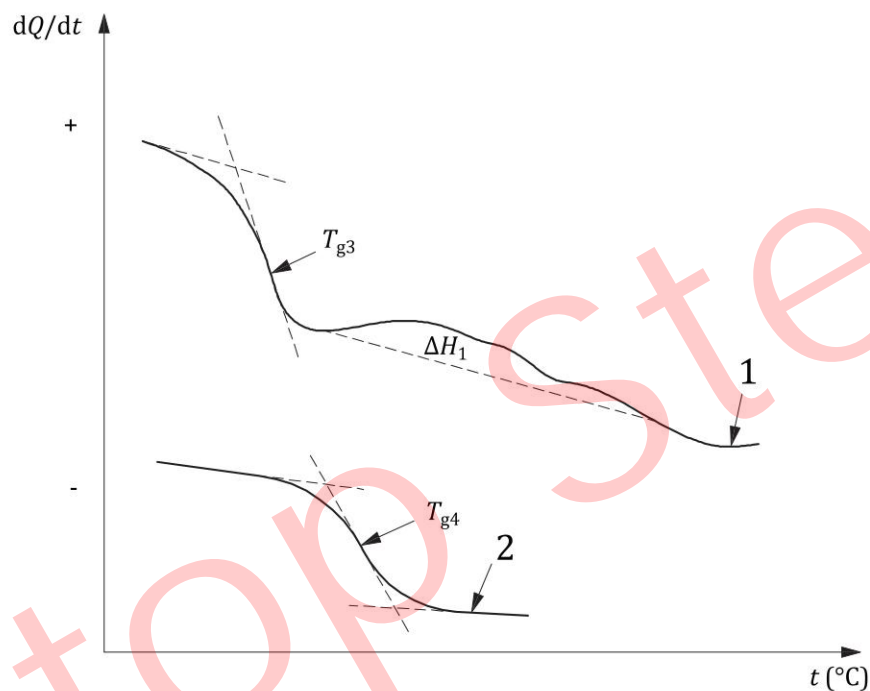

#### Key

- 1 run (b)
- 2 run (c)

Figure D.2 — Examples of thermal scans on coating

#### D.5.3.2 Residual heat of reaction of cured coating

The exothermic heat of reaction,  $\Delta H_1$ , shall be obtained by integrating the exothermic peak of the DSC scan run (b) in [Figure D.2](#).

In a fully cured coating film, no residual heat of reaction should be observed.

The degree of conversion,  $C$ , expressed as a percentage, can be calculated as given in [Formula \(D.2\)](#):

$$C = \frac{\Delta H - \Delta H_1}{\Delta H} \times 100 \quad (\text{D.2})$$

where

$\Delta H$  is the exothermic heat of reaction of the powder; run (b) in [D.3.2](#);

$\Delta H_1$  is the exothermic heat of reaction of the powder; run (b) in [D.5.2](#).

## D.6 Results and test report

Record the following information on uncured and cured material:

- reference to this document;
- type of material and batch number;
- date of test;
- type of DSC equipment;
- for the epoxy powder:  $T_{g1}$ ,  $T_{g2}$ ,  $\Delta H$ ;
- for the epoxy liquids:  $T_{g2}$ ,  $\Delta H$ ;
- for the cured coating film:  $T_{g3}$ ,  $T_{g4}$ ,  $\Delta T_g$ ,  $\Delta H_1$  and  $C$ .

Testing of production coating shall also require the pipe number or identification.

## Annex E (normative)

### Impact test

#### E.1 General

The test shall consist of verifying the strength of the coating by the impact of a punch of defined shape falling directly onto the coating from a fixed height and at a fixed temperature. Carry out the test on pipes or cut samples. Do not carry out this test on pipes with a diameter of less than 50 mm.

#### E.2 Equipment

**E.2.1** Drop-weight testing machine, consisting of the following:

- Straight guide made of steel, aluminium or plastic, rigid and non-deformable, of inside diameter between 40 mm and 60 mm, at least as long as 1,30 m and containing a smooth and even inside surface. Provide the guide with
  - support and levelling devices (for example two spirit levels for the horizontal plane and a plumb line for the vertical plane), and
  - graduated rod, which makes it possible to determine the drop height to an accuracy of 5 mm.

Other guides may be used by agreement.

- Hard steel punch, with a hemispherical head, free from notches, porosity or other surface irregularities and with a diameter of  $25 \text{ mm} \pm 1 \%$ .
- Fix a small metal rod of 6 mm in diameter perpendicular to the flat face of the head and in its centre, where this rod shall be long enough to hold the additional weights required for the tests. Equip the punch with a suitable system for raising it to the required height; the mass of the assembly shall be appropriate to the energy being checked and shall be accurate  $\pm 2 \%$ .
- Weights, formed by metal discs (preferably made of stainless steel) with an outside diameter fitting the internal diameter of the straight guide and incorporating a central hole of a suitable diameter; the mass of each disc shall be accurate to  $\pm 2 \%$ .

#### E.3 Procedure

**E.3.1** The test shall be carried out at a temperature of  $23 \text{ }^\circ\text{C} \pm 3 \text{ }^\circ\text{C}$ . If provisions have been made to perform this test outside this temperature range, adapt the method described, if necessary, to the agreement between the applicator and the purchaser.

**E.3.2** The coated pipe shall be placed on a rigid and stable horizontal support and shall, if necessary, support the pipe interior to reduce its elastic response.

**E.3.3** A holiday detection test shall be carried out prior to the impact test ([Annex B](#)) to identify the defective points and avoid making the impact at these locations.

**E.3.4** For each point of impact, the drop-weight testing machine shall be installed perpendicular to the coating surface so that the loaded punch can fall freely without friction or resistance. Ten impacts shall

be carried out, allowing the weight corresponding to the specified energy to fall from a height of 1 m. The points of impact shall be selected to avoid any protruding welds. Furthermore, the distance from the points of impact to the end of the pipe shall be at least  $1,5 D$  and at least 50 mm apart between the axes of the impacts.

**E.3.5** The holiday detection test shall be performed at each location ([Annex B](#)).

**E.3.6** The hard steel punch shall be checked every 30 impacts. If damaged, it shall be replaced.

#### **E.4 Results and test reports**

If no holidays are recorded on any of the ten impacts, the impact results are accepted.

The test reports shall include at least the following:

- identification of test specimens;
- procedure used;
- instruments used;
- reference to this document;
- weight used;
- date of test;
- test result.

Botop Steel

## Annex F (normative)

### Indentation test

#### F.1 General

The test consists of measuring the indentation of a punch into the coating under fixed conditions of temperature, load and time.

#### F.2 Equipment

**F.2.1 Chamber**, inside ventilated or a circulated bath, thermostatically controlled to  $\pm 2$  °C.

**F.2.2 Penetrometer**, comprised of

- a cylindrical indenter with a diameter of  $1,8 \text{ mm} \pm 0,05 \text{ mm}$ , on the top of which is mounted a weight; the assembly (indenter plus weight) shall produce a force of  $25 \pm 0,5 \text{ N}$ ,
- a dial gauge, or
- another measurement system accurate to  $\pm 0,01 \text{ mm}$ .

#### F.3 Procedure

**F.3.1** The test shall be performed three times on a coupon cut from the pipe or on strips of polyolefin top coat removed from the pipe surface.

**F.3.2** The test sample shall be held within the penetrometer assembly, in the thermostatically controlled chamber and set to the test temperature. The test assembly shall be kept in the chamber for 1 h. The indenter shall be loaded with the force of  $25 \pm 0,5 \text{ N}$  in total into the equipment. The readings on the dial gauge shall be recorded within 5 s (first reading).

**F.3.3** A test duration of 24 h shall be used. The readings of the dial gauge shall be recorded (second reading).

#### F.4 Results and test reports

The resultant indentation shall be calculated as the difference between the dial gauge reading before (first reading) and after the 24 h test duration (second reading). The average of the three samples shall be recorded.

The test reports shall include at least the following:

- identification of test specimens;
- procedure used;
- instruments used;
- reference to this document;

- date of test;
- test results.

Botop Steel



## Annex G (normative)

### UV ageing test and thermal ageing test

#### G.1 UV ageing

##### G.1.1 General

The test shall consist of subjecting PE/PP material test samples to the continuous irradiation of a xenon lamp under given temperature and humidity conditions.

Evaluation shall be performed by assessing the change in the material through the variation in its melt flow rate (MFR) or alternatively by assessing the variation in the tensile strain at break.

##### G.1.2 Equipment

**G.1.2.1 Irradiation chamber**, equipped with a xenon lamp in accordance with ISO 4892-2:2013.

**G.1.2.2 Melt flow tester** (see ISO 1133-1).

**G.1.2.3 Tensile testing equipment** to perform tests in accordance with ISO 527-1 and ISO 527-2.

##### G.1.3 Sampling

The test shall be carried out on samples taken from the top layer coating applied on the pipe free of adhesive residues. Alternatively the test can also be carried out on a sheet/plate sample or on tensile specimens according to ISO 527-2 of 2 mm thickness prepared in accordance with ISO 17855-2 (for PE) and ISO 19069-2 (for PP) shall be used for UV exposure. In case the tensile strain at break is to be tested after UV exposure and sheets/plates are to be exposed, they shall be big enough so that dog-bones according to ISO 527-2 can be prepared from them.

##### G.1.4 Procedure

**G.1.4.1** The test sample(s) shall be exposed under the following conditions:

- artificial weathering in accordance with ISO 4892-2:2013, Table 3, Method A, cycle 1;
- irradiance:  $60 \pm 2 \text{ W/m}^2$  (300 nm to 400 nm) respectively  $0,51 \pm 0,02 \text{ W/m}^2$  (340 nm) using daylight filters;
- black standard temperature ( $65 \text{ }^\circ\text{C} \pm 3 \text{ }^\circ\text{C}$ );
- relative humidity ( $65 \% \pm 5 \%$ );
- spray cycle: 18 min  $\pm$  0,5 min spray, 102 min  $\pm$  0,5 min dry;
- continuous exposure.
- total radiant time:
  - for class A and B materials: 2 210 h;
  - for class C type materials: 1 580 h;

- the selection of the testing times should correspond to a total radiation (full spectrum from 300 nm to 2450 nm) approximately 7 GJ/m<sup>2</sup> for class A and B materials and 5 GJ/m<sup>2</sup> for class C type materials.

**G.1.4.2** Three melt-flow-rate measurements according to ISO 1133-1 or five tensile strain at break measurements according to ISO 527-2 (the testing speed shall be chosen according to ISO 527-1 and in such a way that the strain rate is as close as possible to the one when testing a 1A or 1B type specimens according to ISO 527-2 with 50 mm/min) shall be undertaken on the test samples.

**G.1.4.3** Calculate the MFR after exposure,  $MFR_1$ , as the arithmetic mean of at least three results or the tensile strain at break after exposure,  $\varepsilon_{b1}$ , as the arithmetic mean of at least five results.

**G.1.4.4** Calculate the  $MFR_0$  in accordance with ISO 1133-1 or  $\varepsilon_{b0}$  in accordance with ISO 527-2 from results obtained from testing samples of the identical shape (and way of preparation) which have not been exposed.

### G.1.5 Results and test report

The variation of the MFR,  $\Delta MFR$ , results, expressed as the percentage variation after exposure, shall be calculated using [Formula \(G.1\)](#) and the variation of the tensile strain at break,  $\Delta\varepsilon_b$ , expressed as the percentage variation after exposure using [Formula \(G.2\)](#):

$$\Delta MFR = \frac{MFR_1 - MFR_0}{MFR_0} \times 100 \quad (G.1)$$

where

$MFR_0$  is the melt flow rate measured before exposure;

$MFR_1$  is the melt flow rate measured after exposure.

$$\Delta\varepsilon_b = \frac{\varepsilon_{b1} - \varepsilon_{b0}}{\varepsilon_{b0}} \times 100 \quad (G.2)$$

where

$\varepsilon_{b0}$  is the tensile strain at break measured before exposure;

$\varepsilon_{b1}$  is the tensile strain at break measured after exposure.

The test reports shall include at least the following:

- identification of the number and type of test specimens;
- procedure used;
- instruments used;
- reference to this document;
- date of test;
- test results.

## G.2 Thermal ageing

### G.2.1 General

The test shall consist of subjecting PE/PP material test samples to the effect of dry heat from a thermostatically controlled oven.

Evaluation shall assess the change in the material by the variation in its melt flow rate or the variation in the tensile strain at break.

### G.2.2 Equipment

**G.2.2.1** Oven, thermostatically controlled, with air circulation maintaining a test temperature within  $\pm 3$  °C.

**G.2.2.2** Melt-flow tester (see ISO 1133-1).

**G.2.2.3** Tensile testing equipment to perform tests in accordance with ISO 527-1 and ISO 527-2.

### G.2.3 Sampling

The test shall be carried out on samples taken from the applied top layer coating which is free of adhesive residues. A sheet/plate sample or tensile specimens according to ISO 527-2 of 2 mm thickness prepared in accordance with ISO 17855-2 (for PE) and ISO 19069-2 (for PP) shall be used for thermal ageing exposure. In case the tensile strain at break is to be tested after thermal ageing, the samples to be exposed shall be big enough so that dog-bones in accordance with the recommendations of ISO 527-2, can be prepared from it.

### G.2.4 Procedure

**G.2.4.1** The test temperature and duration shall be in accordance with [Table G.1](#).

**Table G.1 — Temperature and duration of test**

Coating class	Test duration h	Test temperature °C
A	2 400	100 °C $\pm$ 3 °C
B	4 800	100 °C $\pm$ 3 °C
C Design temperature, $T \leq 80$ °C	240	150 °C $\pm$ 3 °C
C Design temperature, $T > 80$ °C	$(T - 70) \times 24$	150 °C $\pm$ 3 °C

**G.2.4.2** Three melt-flow-rate measurements according to ISO 1133-1 or five tensile strain at break measurements according to ISO 527-2 (the testing speed shall be chosen according to ISO 527-1 and in such a way that the strain rate is as close as possible to the one when testing a 1A or 1B type specimens according to ISO 527-2 with 50 mm/min) shall be undertaken on the test samples.

**G.2.4.3** Calculate the MFR after exposure,  $MFR_1$ , as the arithmetic mean of at least three results or the tensile strain at break after exposure,  $\varepsilon_{b1}$  as the arithmetic mean of at least five results.

**G.2.4.4** Calculate the  $MFR_0$  in accordance with ISO 1133-1 or  $\varepsilon_{b0}$  in accordance with ISO 527-2 from results obtained from testing samples of the identical shape (and way of preparation) which have not been exposed.

### G.2.5 Results and test report

The results shall be expressed as the percentage variation of the melt flow rate,  $\Delta MFR$ , after exposure using [Formula \(G.1\)](#).

The tensile strain at break results shall be determined using [Formula \(G.2\)](#).

The test reports shall include at least the following:

- identification of the number and type of test specimens;
- procedure used;
- instruments used;
- type of oven used;
- reference to this document;
- date of test;
- test results.

Botop Steel

## Annex H (normative)

### Cathodic disbondment test

#### H.1 General

The test shall consist of assessing the resistance to disbondment of the coating system with defect when exposed to cathodic polarization.

The test shall be performed on test specimens taken from the coated pipe previously subjected to holiday detection ([Annex B](#)), in which an artificial defect of a defined size has been drilled.

During production, the test may be performed on the coated pipe without cutting test specimens.

#### H.2 Equipment

**H.2.1 Potentiostat**, accuracy 10 mV.

**H.2.2 Heating equipment controllable to within 3 °C** (e.g. hotplate with sand bath, oven).

**H.2.3 Reference electrode.** Saturated Ag/AgCl electrode (Ag/AgCl/sat. KCl) shall be the standard of reference in these test method. If other reference electrode is used, applied potential shall be adjusted. The accuracy of the reference electrode shall be checked prior to use with an appropriate method according to recommendation of the electrode manufacturer.

**H.2.4 Anode** (counter electrode), e.g. platinum wire of 0,8 mm to 1,0 mm nominal diameter, platinised titanium.

The ratio of the immersed area of anode to the area of working electrode (drilled holiday) should be greater than 2.

**H.2.5 Test vessel** i.e. plastic or glass cylinder, of 75 to 100 mm internal diameter and sufficient height to contain minimum 300 ml of electrolyte.

**H.2.6 Plastic cover** with inlets for reference and counter electrodes.

**H.2.7 Sodium chloride solution**, 3 mass % in deionized or distilled water (electrolyte).

**H.2.8 Material for sealing the test cell** (sealant).

**H.2.9 Temperature measuring device**, accuracy 1 °C (e.g. thermocouple, contact thermometer).

**H.2.10 Utility knife.**

**H.2.11 Drill bit**, 6 mm.

**H.2.12 Calliper gauge**, accuracy 0,1 mm.

### H.3 Test specimens

The test shall be performed on specimens taken from a pipe ring or on tube for smaller than NPS 4 diameter pipe. Specimens from test rings shall be minimum 100 mm × 100 mm × the pipe wall thickness, three specimens shall be tested for each test condition. Cathodic disbondment for each specimen and the average of the three specimens tested shall be reported.

During PPT and production, the test may be performed on a coated pipe without cutting the pipe, on one specimen. If the test is carried out directly on the pipe, the correlation between the results obtained on the specimen and on the pipe shall be demonstrated by the applicator.

### H.4 Procedure

**H.4.1** Use only test specimens that are confirmed to be holiday-free using a holiday detector as described in [Annex B](#). Measure and record the average coating thickness of the sample area where the cathodic disbondment test shall be carried out.

**H.4.2** Drill a 6 mm diameter holiday in the centre of the test specimen through the coating to expose the steel substrate. Ensure the depth of the holiday is minimal and that no coating is visible within the area of holiday. Avoid excessive penetration into the steel substrate.

**H.4.3** Centre the cylinder over the holiday. Apply a sealant to form a water-resistant seal or by the use of an o-ring and a clamping device.

**H.4.4** Fill the cylinder to a height of minimum 70 mm with at least 300 ml of the sodium chloride solution that has been preheated to the test temperature.

**H.4.5** Mark the solution level on the cylinder.

**H.4.6** Insert the anode into the solution and connect to the counter electrode lead (positive lead) from the potentiostat.

**H.4.7** Insert the reference electrode into the solution within 10 mm above the holiday and 20 mm away from the anode.

**H.4.8** Connect the working electrode lead (negative lead) from the potentiostat to a bare spot prepared on the test specimen.

**H.4.9** For test at elevated temperature, heat the test specimen to the required test temperature in an oven or on a hot plate/sand bath.

**H.4.10** Once test temperature has been reached and temperature of the solution is stable, apply voltage (negative with respect to the Ag/AgCl/sat. KCl reference electrode) to the test specimen, and maintain at a constant temperature under one or more of the following test conditions, as given in [Tables 7](#) and [9](#).

- 1,38 V ± 0,15 V, 23 °C ± 3 °C, for 28 d;
- 3,38 V ± 0,15 V, 65 °C ± 3 °C, for 24 h;
- 1,38 V ± 0,15 V, maximum operation temperature (maximum of 90 °C, see [Table 7](#)), for 28 d.

NOTE 1 A Ag/AgCl/sat.KCl reading of -1,38 V is equivalent to Ag/AgCl/3M KCl reading of -1,39 V and to sat. Cu/CuSO<sub>4</sub> reading of -1,5 V (at 25 °C).

NOTE 2 A temperature coefficient of +1 mV/°C might be considered while using Ag/AgCl/sat.KCl and Ag/AgCl/3M KCl reference electrodes at elevated temperatures.

**H.4.11** Check the solution level daily and maintain at the marked level by the addition of deionized or distilled water in the cell as required (see [Figures H.1](#) and [H.2](#)).

**H.4.12** The test temperature shall be checked on the steel using a thermocouple. The coating shall be removed on a small area outside the cylinder and the thermocouple shall be installed maximum 70 mm away from the holiday to make the temperature measurement. A proper contact between thermocouple and steel shall be ensured.

The temperature in the electrolyte solution shall be checked with a thermometer. The thermometer shall be inserted into the solution within 10 mm above the holiday and half distance between holiday and cylinder wall. The solution temperature shall remain stable within  $\pm 3$  °C. If the temperature deviation is higher, the test cylinder shall be isolated.

**H.4.13** Upon test completion, dismantle the test cell and air cool the specimen to  $23$  °C  $\pm$   $3$  °C.

**H.4.14** Remove the polyolefin layer to the remaining thickness not higher than 1 mm by abrading or other appropriate method and make 8 radial cuts through the epoxy layer to the substrate using the utility knife. Such cuts shall extend at least 20 mm from the centre of the holiday.

**H.4.15** Insert the tip of the blade of the utility knife under the epoxy layer at the holiday. Chip off the epoxy coating using a levering action. Continue until the coating demonstrates a definite resistance to the levering action.

**H.4.16** Measure the disbonded distance from the edge of the original holiday along each radial cut with a calliper, and average such measured values.

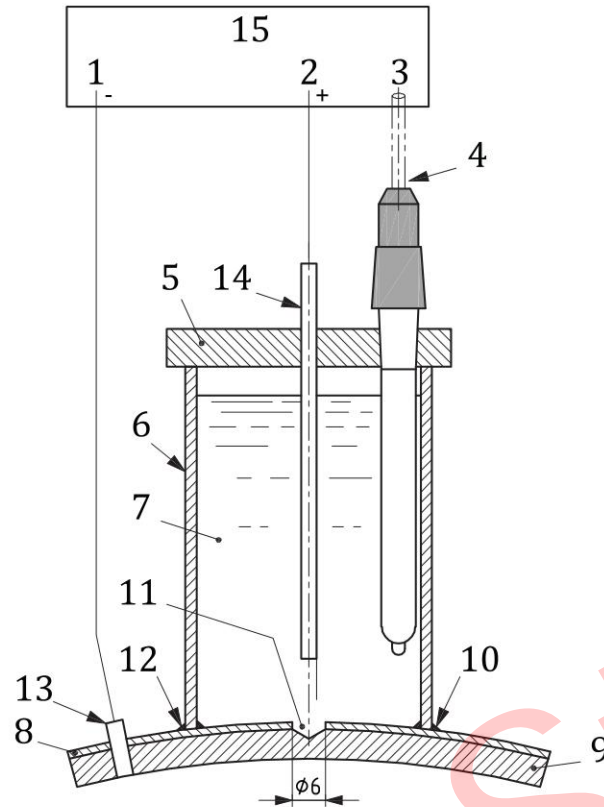

**Key**

- |   |  |    |                                  |
|---|--|----|----------------------------------|
| 1 | working electrode (cathode)              | 9  | steel test piece                 |
| 2 | counter electrode (anode)                | 10 | sealing material                 |
| 3 | reference electrode shielded cable       | 11 | holiday (artificial defect)      |
| 4 | reference electrode                      | 12 | sealing material                 |
| 5 | plastic cover                            | 13 | electrical connection to cathode |
| 6 | cylinder (minimum internal $\phi 75$ mm) | 14 | anode (counter electrode)        |
| 7 | electrolyte $\geq 300$ ml                | 15 | potentiostat                     |
| 8 | coating                                  |    |                                  |

**Figure H.1 — Electrolytic cell for NPS 4 and larger-diameter pipe**

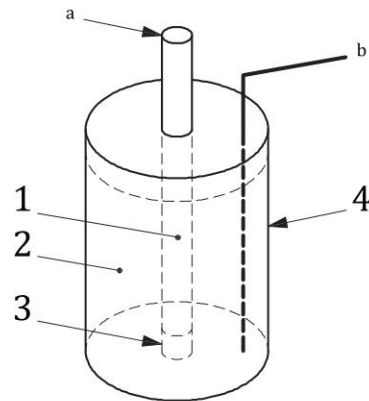

**Key**

- 1 holiday
- 2 electrolyte
- 3 end cap
- 4 beaker
- a To negative lead (-).
- b To positive lead (+).

**Figure H.2 — Electrolytic cell for pipe smaller than NPS 4 diameter pipe**

**H.5 Results and test report**

The results shall consist of recording the average disbondment value, expressed in millimetres.

Testing of production coating requires pipe number or identification.

The test reports shall include at least the following:

- identification of test specimens;
- thickness of the applied coating;
- procedure used;
- instruments used;
- reference to this document;
- date of test;
- test voltage;
- test duration;
- test temperature;
- test result.

## Annex I (normative)

### Flexibility test

#### I.1 General

The test shall consist of assessing the flexibility of three-layer polyolefin coatings, applied to a bare steel substrate.

#### I.2 Equipment

I.2.1 Hydraulic press.

I.2.2 Bending mandrels, with fixed radii.

I.2.3 Freezer.

I.2.4 Strain gauges, if applicable.

I.2.5 Electric timing device, or stopwatch, capable of measuring 0,1 s intervals.

I.2.6 Thermometer.

#### I.3 Test specimen

Test samples shall be cold cut from a pipe ring with a minimum length of 200 mm parallel to the axis of the pipe. The width shall be approximately 25 mm.

#### I.4 Procedure

I.4.1 Flexibility test shall be conducted on three test specimens and each result recorded.

I.4.2 The coating and the metal on the edge of the test sample shall be smoothed to remove any potential stress risers.

I.4.3 The test specimens shall be placed in the freezer, cooled to between  $-2\text{ }^{\circ}\text{C}$  and  $0\text{ }^{\circ}\text{C}$ , and held at that temperature for a minimum of 1 h.

I.4.4 The effective sample thickness,  $d$ , which includes the actual sample thickness and any curvature, shall be determined by placing the specimen on a flat surface and measuring the effective thickness shown in [Figure I.1](#).

Dimensions in millimetres

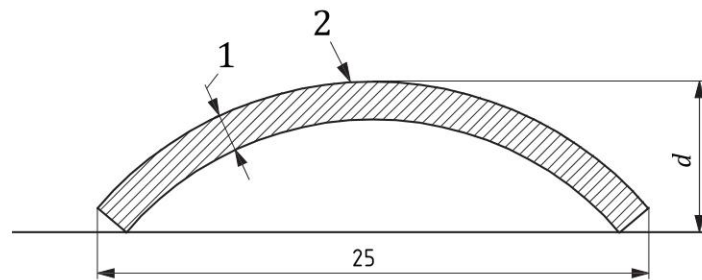
**Key**

- 1 pipe wall thickness
- 2 coating

**Figure I.1 — Effective strap thickness diagram**

**I.4.5** The mandrel radius,  $r$ , expressed in millimetres, which corresponds to an angle of deflection of  $2^\circ$  per pipe diameter length, shall be determined by using [Formula \(I.1\)](#):

$$r = 28,15 \times d \quad (\text{I.1})$$

where  $d$  is the effective sample thickness, expressed in millimetres.

**I.4.6** The test samples shall be bent over a mandrel whose radius is not larger than that determined in accordance with [Formula \(I.1\)](#).

**I.4.7** The specimens shall be bent such that the operation lasts no longer than 10 s and is completed within 30 s of the test samples having been removed from the freezer.

**I.4.8** The bent test samples shall be warmed to  $23 \text{ }^\circ\text{C} \pm 3 \text{ }^\circ\text{C}$ , and held within this temperature range for a minimum of 2 h. Within the next hour, visually inspect it for the presence of cracks.

**NOTE** If the sample exhibits peaking, the percentage strain can be calculated by the use of strain gauges attached to the test specimen.

**I.5 Result and test report**

The presence of cracking shall constitute a failure in accordance with [Table 7](#).

The test reports shall include at least the following:

- identification of test specimens;
- procedure used;
- instruments used;
- reference to this document;
- total coating thickness;
- date of test;
- test results for any test sample;
- bent area close up picture of the coating/epoxy interface of any sample.

## Annex J (normative)

### Gel time of the epoxy powder

#### J.1 General

The test shall consist of assessing the gel time of the epoxy powder used in the three-layer coating.

#### J.2 Equipment

The equipment shall consist of the following:

J.2.1 **Hotplate**, controllable to within 3 °C.

J.2.2 **Metal plate**, for placing on top of the hotplate.

J.2.3 **Stopwatch or electric timing device**, capable of measuring 0,1 s intervals.

J.2.4 **Draw-down tool** (see [Figure J.1](#)).

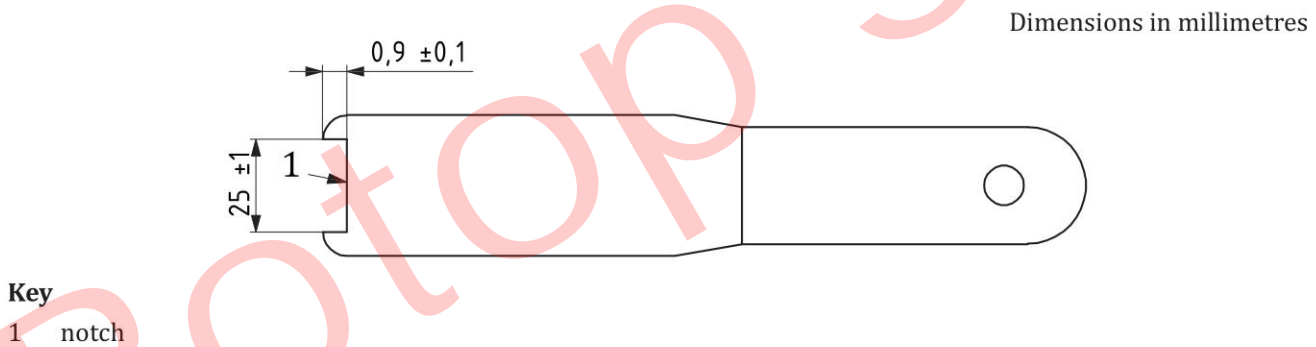

Figure J.1 — Draw-down tool

#### J.3 Procedure

J.3.1 Three tests shall be conducted and the results averaged.

J.3.2 Heat and maintain the temperature of the metal plate surface that will be in contact with the powder at a temperature of 205 °C ± 3 °C. If FBE used has an application temperature <200 °C the metal plate surface shall be maintained at a temperature of 180 °C ± 3 °C.

J.3.3 Cover the bottom 25 mm of the draw-down tool with epoxy powder.

J.3.4 In a smooth motion, deposit and draw the epoxy powder across the metal plate while holding the tool at an angle of approximately 45° to the metal plate, thereby creating a tongue of epoxy powder approximately 25 mm wide.

NOTE The target thickness of the cured film is 350 and 500  $\mu\text{m}$ .

**J.3.5** Start the timing device at the instant of powder deposition on the metal plate.

**J.3.6** The draw-down tool is held at an angle of approximately  $45^\circ$  to the hotplate surface, in a manner that allows most of the tool's mass weight to be borne on the plate. Repeatedly draw the edge of the tool through the melted epoxy powder. Stop the timing device when the tool rides up on the gelled powder and no longer contacts the metal plate, as illustrated in [Figure J.2](#).

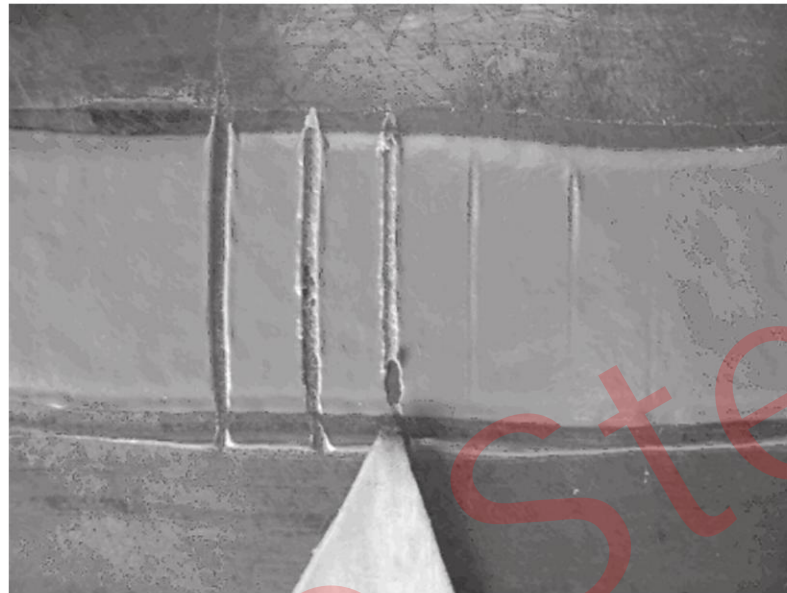

**Figure J.2 — Gel time assessment**

#### **J.4 Results and test reports**

The test reports shall include at least the following:

- identification of test specimens (i.e. epoxy powder batch number);
- procedure used including temperature indicated in [J.3.2](#);
- reference to this document;
- date of testing;
- test results (i.e. gel time, expressed in seconds).

## Annex K (normative)

### Total volatile/moisture content of the epoxy powder — Mass loss

#### K.1 General

The test shall consist of assessing the loss of volatiles from the epoxy powder.

#### K.2 Procedure A — Manual method

The equipment shall consist of the following:

##### K.2.1 Equipment

**K.2.1.1 Oven**, controllable to within 3 °C.

**K.2.1.2 Balance**, accurate to 0,001 g.

**K.2.1.3 Desiccator**.

**K.2.1.4 Sample container**.

##### K.2.2 Procedure

**K.2.2.1** Weigh the sample container to the nearest 0,001 g. Transfer approximately 10 g of epoxy powder into the sample container and spread evenly. Weigh the sample container and epoxy powder to the nearest 0,001 g.

**K.2.2.2** Place the sample container with the epoxy powder into the oven for a maximum of 2 h at 105 °C ± 3 °C.

**K.2.2.3** Remove the container from the oven and place it in a desiccator to cool. Weigh the sample container when it has cooled to 20 °C ± 3 °C, and then return it to the desiccator; repeat at intervals of 60 min ± 10 min until two consecutive mass determinations are within 0,001 g.

**K.2.2.4** Calculate the percentage of moisture,  $w_m$ , expressed as a percentage using [Formula \(K.1\)](#):

$$w_m = \frac{M_I - M_F}{M_I - M_C} \times 100 \quad (\text{K.1})$$

where

$M_I$  is the initial mass of the sample container and epoxy powder, expressed in grams;

$M_F$  is the final mass of the sample container and epoxy powder, expressed in grams;

$M_C$  is the mass of the sample container, expressed in grams.

### **K.3 Procedure B — Automatic procedure**

The moisture content of the epoxy powder shall be determined using a machine that automatically determines moisture content by mass loss.

### **K.4 Results and test reports**

The test reports shall include at least the following:

- identification of test specimens (i.e. epoxy powder batch number);
- date of test;
- procedure used;
- instruments used;
- reference to this document;
- test results (i.e. percentage of moisture content).

Botop Steel

## Annex L (normative)

### Hot water immersion test

#### L.1 General

The test shall consist of a hot water immersion procedure to test the resistance of factory-applied, three-layer polyolefin coating on pipe to loss of adhesion from a steel substrate in a wet environment.

The test shall be performed on test specimens cold-cut from the coated pipe previously subjected to holiday detection ([Annex B](#)) and is applicable to system qualification testing, PPT and PQT, where required.

The test may be performed on the coated pipe without cutting test specimens.

#### L.2 Equipment

**L.2.1 Oven or heating bath**, controllable to  $80\text{ °C} \pm 3\text{ °C}$ .

**L.2.2 Vessel**, of a suitable size to accommodate the samples, with a cover to minimize evaporation.

**L.2.3 Utility knife or chisel.**

#### L.3 Sample preparation

**L.3.1** For pipes with an outer diameter of up to 76 mm (3 in), test samples shall be cold-cut into 150 mm pipe rings with the applied factory coating.

**L.3.2** For larger pipes, for Coating System Qualification and PQT, test samples shall be cold-cut into 150 mm × 100 mm segments, with the shorter side transverse to the pipe axis.

During PPT, the test may be performed on specimens from test rings or on the coated pipe without cutting test specimens. If the test is carried out directly on the pipe, the correlation between the results obtained on the specimen and on the pipe shall be demonstrated by the applicator.

**L.3.3** The exposed surfaces shall be prepared by wet grinding with 120-grit abrasive paper. The exposed coating faces shall not be chamfered or extended beyond the steel edge. Exposed faces shall not be covered by any protection during testing.

**L.3.4** Three samples shall be prepared from the same pipe for each test.

#### L.4 Test procedure

**L.4.1** Samples shall be inspected for holidays with a holiday detector set at  $25 \pm 2,5\text{ kV}$ , thicknesses measured and recorded, and visually inspected for voids and visible detachment of the adhesive layer. Samples with holidays or adhesive detachment shall be discarded. An adhesive tape may be used to prevent high voltage spark bridging over to the steel from the edges of the test sample. Before the immersion, adhesive tape, if applied, shall be removed.



**L.4.2** Place the specimens in a vessel filled with tap water already preheated to 80 °C. Ensure that the test specimens are covered with the water by at least 50 mm. Maintain the water and samples at 80 °C for 48 h.

**L.4.3** After the conditioning period extract the samples from the bath, dry them with paper or tissue and examine them within 1 h after they have cooled to room temperature. Examine again after 24 h the samples at room temperature, if applicable.

**L.4.4** Visually examine the samples for loss of adhesion at the coating/substrate interface along all four sides. Do not take into account any coating disbondment for 5 mm on each side of the corners of a sample. At any area where loss of adhesion to the substrate has occurred use a sharp knife at the coating/substrate interface to assess for loss of adhesion, by pressing the blade into the interface and rotating it on the longitudinal axis, trying to lift off any of the coating that has lost adhesion.

If any loss of adhesion is found visually or by use of the knife, remove the non-adherent coating system in that area, with a sharp knife or chisel, in order to expose the substrate under the disbonded coating. Measure the maximum and average depth of loss of adhesion, in mm, of the three-layer polyolefin coating system in the disbonded area.

**L.4.5** Take photographs of the overall sample tested, and close-up photographs of any areas of loss of adhesion of the three-layer polyolefin coating system.

## **L.5 Results and test reports**

Record the average and the maximum loss of adhesion of the coating in all areas where disbondment of the coating has occurred after cooling and after 24 h, if applicable (except for a distance of 5 mm each side of the corners of the sample).

Enclose the photographs taken, with the results.

The test reports shall at least include:

- identification of test specimens with thickness average and holiday detector control;
- procedure used;
- instruments used;
- reference to this document;
- pictures;
- date (time) of the test (start of the test, end of the test, end of cooling, +24 h if applicable);
- test results after cooling and after 24 h.

## Annex M (normative)

### Density of epoxy powder

#### M.1 General

The test shall consist of evaluating the density of the epoxy powder at a temperature of  $23\text{ °C} \pm 3\text{ °C}$ .

#### M.2 Procedure A — Manual procedure

##### M.2.1 Equipment

The equipment shall consist of the following:

**M.2.1.1 Balance**, accurate to 0,01 g.

**M.2.1.2 Flask**, 100 ml volumetric.

**M.2.1.3 Mineral spirits**.

##### M.2.2 Procedure

**M.2.2.1** Weigh the flask to the nearest 0,01 g.

**M.2.2.2** Add approximately 20 g of epoxy powder to the flask and weigh the flask plus epoxy powder to the nearest 0,01 g.

**M.2.2.3** Add sufficient mineral spirit to cover and wet the epoxy powder. Stopper the flask, and agitate it for several minutes, ensuring that neither air pockets nor lumps of powder exist.

**M.2.2.4** Wash the stopper and walls of the flask with mineral spirits until they are free of powder and the flask is filled to the 100 ml level.

**M.2.2.5** Weigh the flask plus epoxy powder and mineral spirits to the nearest 0,01 g.

**M.2.2.6** Empty the flask. Clean and dry the flask.

**M.2.2.7** Add 100 ml of mineral spirits and weigh the flask plus mineral spirits to the nearest 0,01 g.

**M.2.2.8** Calculate the density of the mineral spirit,  $\rho_s$ , expressed in grams per cubic centimetre, using Formula (N.1):

$$\rho_s = \frac{(M_{fs} - M_f)}{0,1} \quad (\text{M.1})$$

where

$M_{fs}$  is the mass of the flask plus mineral spirit, expressed in grams;

$M_f$  is the mass of the flask, expressed in grams.

**M.2.2.9** Calculate the density of the epoxy powder,  $\rho_p$ , expressed in grams per cubic centimetre, using [Formula \(M.2\)](#):

$$\rho_p = \frac{(M_{fp} - M_f)}{0,1 - \left( \frac{M_{fps} - M_{fp}}{\rho_s} \right)} \quad (\text{M.2})$$

where

$M_{fp}$  is the mass of the flask plus epoxy powder, expressed in grams;

$M_f$  is the mass of the flask, expressed in grams;

$M_{fps}$  is the mass of the flask plus epoxy powder and mineral spirits, expressed in grams;

$\rho_s$  is the density of the mineral spirits, expressed in grams per cubic centimetre.

### M.3 Procedure B — Automatic procedure

The density of the epoxy powder shall be determined using an air or helium pycnometer in accordance with ISO 8130-2 or ISO 8130-3.

### M.4 Results and test reports

The test reports shall include at least the following:

- epoxy powder batch number;
- date of testing;
- procedure used;
- type of pycnometer used for Procedure B;
- density of epoxy powder, expressed in grams per cubic centimetre.

## Bibliography

- [1] ISO 294-1, *Plastics — Injection moulding of test specimens of thermoplastic materials — Part 1: General principles, and moulding of multipurpose and bar test specimens*
- [2] ISO 9001, *Quality management systems — Requirements*
- [3] ISO 13623:2017, *Petroleum and natural gas industries — Pipeline transportation systems*
- [4] ISO 14001, *Environmental management systems — Requirements with guidance for use*
- [5] ASTM E29, *Standard Practice for Using Significant Digits in Test Data to Determine Conformance with Specifications*
- [6] Joint Surface Preparation Standard NACE No. 1/SSPC-SP 5, *White Metal Blast Cleaning*
- [7] Joint Surface Preparation Standard NACE No. 2/SSPC-SP 10, *Near-White Metal Blast Cleaning*

Botop Steel

<https://www.botopsteelpipe.com>

Botop Steel