



Designation: A770/A770M – 03 (Reapproved 2018)

## Standard Specification for Through-Thickness Tension Testing of Steel Plates for Special Applications<sup>1</sup>

This standard is issued under the fixed designation A770/A770M; the number immediately following the designation indicates the year of original adoption or, in the case of revision, the year of last revision. A number in parentheses indicates the year of last reapproval. A superscript epsilon ( $\epsilon$ ) indicates an editorial change since the last revision or reapproval.

*This standard has been approved for use by agencies of the U.S. Department of Defense.*

### 1. Scope

1.1 This specification<sup>2</sup> covers the procedures and acceptance standards for the determination of reduction of area using a tension test specimen whose axis is perpendicular to the rolled surfaces of steel plates 1 in. [25 mm] and greater in thickness. The principal purpose of the testing is to provide a measure of the resistance of a steel plate to lamellar tearing. (See [Appendix X1](#).)

1.2 The values stated in either inch-pound units or SI units are to be regarded as standard. Within the text, the SI units are shown in brackets. The values stated in each system are not exact equivalents; therefore, each system must be used independently of the other. Combining values from the two systems may result in nonconformance with the specification.

1.3 This specification is expressed in both inch-pound and SI units. However, unless the order specifies the applicable “M” specification designation (SI units), the material shall be furnished to inch-pound units.

1.4 *This international standard was developed in accordance with internationally recognized principles on standardization established in the Decision on Principles for the Development of International Standards, Guides and Recommendations issued by the World Trade Organization Technical Barriers to Trade (TBT) Committee.*

### 2. Referenced Documents

#### 2.1 ASTM Standards:<sup>3</sup>

[A370 Test Methods and Definitions for Mechanical Testing of Steel Products](#)

<sup>1</sup> This specification is under the jurisdiction of ASTM Committee A01 on Steel, Stainless Steel and Related Alloys and is the direct responsibility of Subcommittee A01.11 on Steel Plates for Boilers and Pressure Vessels.

Current edition approved Sept. 1, 2018. Published September 2018. Originally approved in 1980. Last previous edition approved in 2012 as A770/A770M – 03 (2012) <sup>$\epsilon$ 1</sup>. DOI: 10.1520/A0770\_A0770M-03R18.

<sup>2</sup> For ASME Boiler and Pressure Vessel Code applications, see related Specification SA-770/SA-770M in Section II of that Code.

<sup>3</sup> For referenced ASTM standards, visit the ASTM website, [www.astm.org](http://www.astm.org), or contact ASTM Customer Service at [service@astm.org](mailto:service@astm.org). For *Annual Book of ASTM Standards* volume information, refer to the standard’s Document Summary page on the ASTM website.

### 3. Ordering Information

3.1 The inquiry and order shall include the following, if required:

3.1.1 Supplementary requirements that are available to meet end use requirements (see S1 through S5).

3.1.2 Special requirements agreed upon between the manufacturer and the purchaser.

### 4. Tension Tests

#### 4.1 Number of Tests:

4.1.1 Two tests shall be required from each plate-as-rolled, except for plates subjected to heat treatment by quenching and tempering. Two tests shall be required from each quenched-and-tempered plate. The tests shall be representative of the plate in its final condition.

4.1.2 When plates are furnished by the manufacturer in an unheat-treated condition and qualified by heat-treated specimens (including normalized, normalized and tempered, and quenched and tempered), two tests shall be required from each plate-as-rolled.

NOTE 1—The term “plate-as-rolled” refers to the unit plate rolled from a slab or directly from an ingot. It does not refer to the condition of the plate.

4.2 *Location of Test Coupons*—Take one test coupon at each end of each plate as defined in [4.1](#). Take the test coupons from the center of the plate width.

4.3 *Orientation of Test Specimens*—The longitudinal axis of the reduced section of the test specimens shall be perpendicular to the rolled surface of the plate.

#### 4.4 Preparation of Test Specimens:

4.4.1 *Welded Prolongations*—When required, join welded prolongations to the surface(s) of the plate being tested. The joining method used shall be one which results in a minimal heat-affected zone in the portion of the plate to be tested. Shielded metal arc, friction, stud, or electron-beam welding methods have proven to be suitable.

#### 4.4.2 Standard Test Specimens:

4.4.2.1 Three types of standard round tension test specimens are shown in [Fig. 1](#) and [Table 1](#). For Types 1 and 2 specimens, locate the center of the length of the reduced section at the

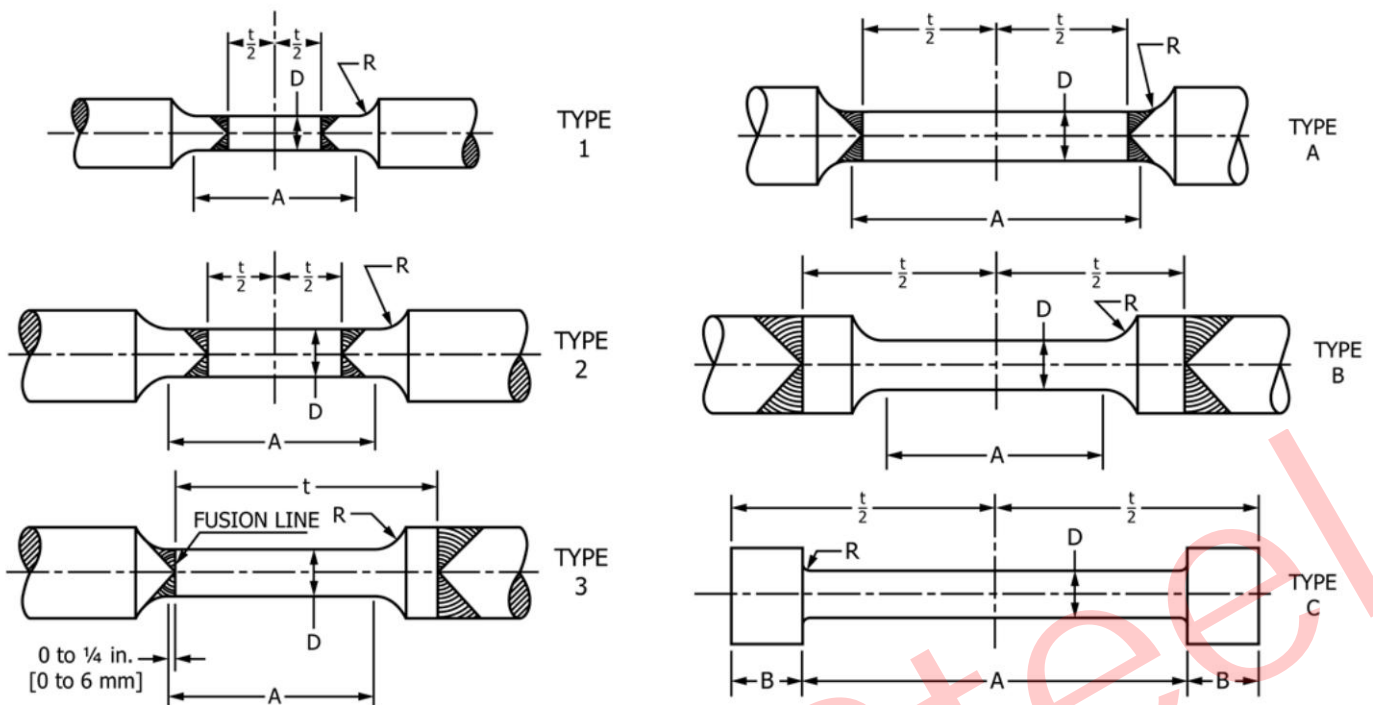

NOTE 1—For Type 3 only one welded prolongation may be needed, depending upon plate thickness.

FIG. 1 Standard Round Tension Test Specimens

TABLE 1 Schedule of Standard Test Specimens, Inches [Millimetres]<sup>a</sup>

	Specimen Type		
	1	2	3
Plate thickness ( <i>t</i> )	$1 \leq t \leq 1\frac{1}{4}$	$1 < t \leq 2$	$2 < t$
Diameter ( <i>D</i> )	0.350 [8.75]	0.500 [12.5]	0.500 [12.5]
Radius, minimum ( <i>R</i> )	$\frac{1}{4}$ [6]	$\frac{3}{8}$ [10]	$\frac{3}{8}$ [10]
Length of reduced section ( <i>A</i> )	$1\frac{3}{4}$ [45]	$2\frac{1}{4}$ [60]	$2\frac{1}{4}$ [60]

<sup>a</sup> See Test Methods and Definitions A370 (Fig. 5 for further details and Fig. 6 for various types of ends).

approximate mid-point of the plate thickness. For Type 3 specimens, locate the weld fusion line of one plate surface within  $\frac{1}{4}$  in. [6 mm] of one end of the reduced section.

4.4.2.2 For plates from 1 in. [25 mm] to  $1\frac{1}{4}$  in. [32 mm] inclusive in thickness, use either the 0.350-in. [8.75-mm] Type 1 specimen or the 0.500-in. [12.5-mm] Type 2 specimen.

4.4.2.3 For plates over  $1\frac{1}{4}$  in. to 2 in. [50 mm] inclusive in thickness, use the 0.500-in. [12.5-mm] Type 2 specimen.

4.4.2.4 For plates greater than 2 in. [50 mm] in thickness, use the Type 3 specimen.

4.4.3 *Alternative Test Specimens*—The alternative test specimens in Fig. 2 and Table 2 may be used in place of the standard specimens in Fig. 1 and Table 1.

4.4.3.1 For plates over 2 in. [50 mm] in thickness, Type A or Type B specimens may be used. The Type A specimen provides a reduced section length greater than the plate thickness. The Type B specimen provides a reduced section length of  $2\frac{1}{4}$  in. [57 mm] with its center at the mid-thickness of the plate. Over a minimum plate thickness determined by the specimen end configuration, no welded prolongations may be needed for the Type B specimen. For plates over  $4\frac{1}{4}$  in. [108 mm] in

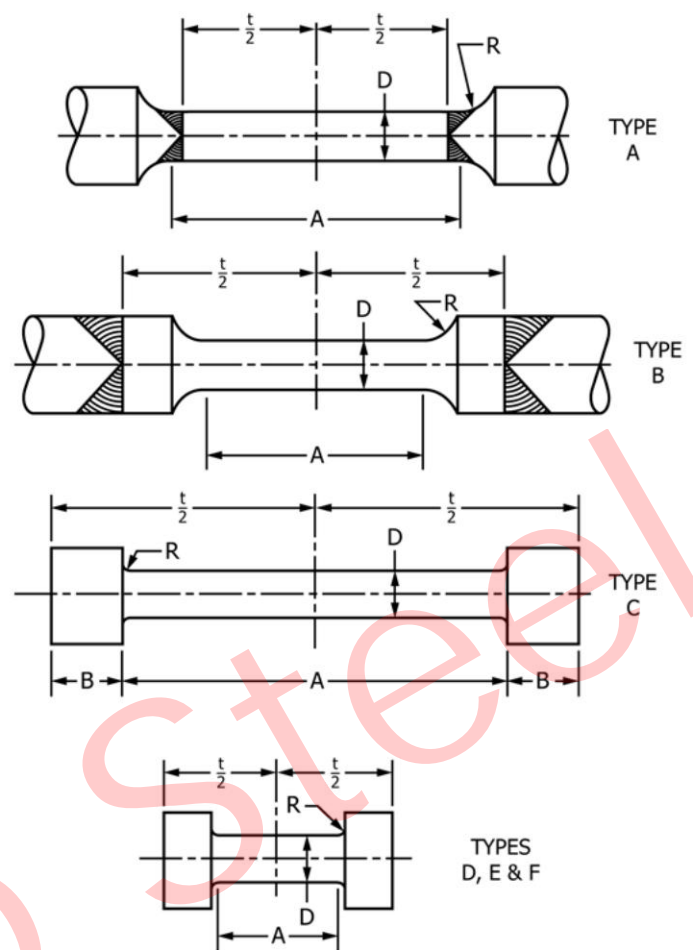

FIG. 2 Alternative Tension Test Specimens

thickness, the Type C specimen may be used. For plates over 6 in. [150 mm] in thickness, a series of two or more Type A or Type C specimens with reduced sections of 4 in. [100 mm] or less may be used to cover the full thickness of the plate. The number of tests required will depend upon the thickness of the plate being tested and the reduced section length selected.

4.4.3.2 For plates over 1 in. [25 mm] in thickness, a series of button-head specimens shown in Fig. 2 and Table 2 may be used. The test specimen type to be used, Type D, Type E, or Type F, is determined by the nominal plate thickness as described in Table 2. A series of two or more Type F specimens may be used to cover the full thickness of the plate. The length of the reduced section (*A*), as shown in Fig. 2 and specified in Table 2, is the length of the reduced section excluding the machined radius (*R*). Within the plate thickness dimension specified for each test specimen type, either the button-head thickness, the reduced section length, or the machined radius may be varied. In all cases, the minimum length of the reduced section must be as specified in Table 2 to maintain a minimum length to diameter ratio (see Appendix X2.2).

## 5. Acceptance Standards

5.1 Each tension test shall have a minimum reduction of area no less than 20 %. If the reduction of area of both tests is less than 20 %, no retest shall be permitted. If the reduction of

**TABLE 2 Schedule of Alternative Test Specimens, Inches [Millimetres]**

	Specimen Type					
	A <sup>A</sup>	B <sup>A</sup>	C <sup>B</sup>	D	E	F
Plate thickness ( <i>t</i> )	2 < <i>t</i> [50 < <i>t</i> ]	2 < <i>t</i> [50 < <i>t</i> ]	4¼ < <i>t</i> [108 < <i>t</i> ]	1 ≤ <i>t</i> ≤ 1 ¾ [25 ≤ <i>t</i> ≤ 45]	1¾ < <i>t</i> ≤ 2½ [45 ≤ <i>t</i> ≤ 64]	2½ < <i>t</i> [64 < <i>t</i> ]
Diameter ( <i>D</i> )	0.500 [12.5]	0.500 [12.5]	0.500 [12.5]	0.250 [6.25] <sup>C</sup> ± 0.005 [0.10]	0.350 [8.75] <sup>C</sup> ± 0.007 [0.18]	0.500 [12.5] <sup>C</sup> ± 0.010 [0.25]
Radius, min ( <i>R</i> )	¾ [10]	¾ [10]	¼ [2]	optional	optional	optional
Length of reduced section, min( <i>A</i> )	<i>t</i> + ¼ min [ <i>t</i> + 6]	2¼ [60]	<i>t</i> – 1½ [ <i>t</i> – 38]	0.625 [16]	0.875 [22]	1.250 [32]

<sup>A</sup> See Test Methods and Definitions A370 (Fig. 5 for further details and Fig. 6 for various types of ends).

<sup>B</sup> See Test Methods and Definitions A370 (Fig. 6, specimen 3 for further details).

<sup>C</sup> The reduced section may have a gradual taper from the ends toward the center, with the ends not more than 1 % larger in diameter than the center (controlling dimension).

area of one of the two tests from a plate is less than 20 %, one retest of two additional specimens taken from a location adjacent to the specimen that failed may be made, and both of these additional specimens shall have a reduction of area of 20 % or more.

5.2 Failures occurring in the prolongations, the weld, or in the fusion line shall be considered as a “no-test,” and an additional specimen shall be tested.

## 6. Marking

6.1 Plates accepted in accordance with this specification shall be identified by stamping or stenciling ZT adjacent to the marking required by the applicable product specification.

## 7. Keywords

7.1 lamellar tearing; special steel-making processes; steel plate; through-thickness tension testing

## SUPPLEMENTARY REQUIREMENTS

These requirements apply only when specified by the purchaser.

### S1. Tensile Strength Requirements

S1.1 Tensile strength shall conform to a minimum value which is subject to agreement between the manufacturer and purchaser.

### S2. Yield Strength Requirements

S2.1 Yield strength, for plates 2 in. [50 mm] and over in thickness, shall conform to a minimum value which is subject to agreement between the manufacturer and purchaser.

### S3. Reduction of Area Requirements

S3.1 A minimum reduction of area limit higher than that in 5.1 may be specified subject to agreement between the manufacturer and purchaser.

### S4. Number of Tests

S4.1 A greater number of tests than indicated in 4.1 may be specified subject to agreement between the manufacturer and purchaser.

### S5. Location of Test Coupons

S5.1 Test coupons from locations in addition to those specified in 4.2 may be specified subject to agreement between the manufacturer and purchaser.

**APPENDIXES****(Nonmandatory Information)****X1. LAMELLAR TEARING ADJACENT TO WELDS****X1.1 Introduction**

X1.1.1 Lamellar tearing is a particular type of cracking that occurs under the weld of a steel plate weldment. It is generally caused by strain induced in the thickness direction resulting from shrinkage of the weld deposit and by the restraint imposed by the components that comprise the weldment. High restraint increases the possibility of lamellar tearing. However, lamellar tearing is not solely confined to highly restrained weldments. Lamellar tearing may also result from loads on the plate surface.

**X1.2 Characteristics of Lamellar Tearing**

X1.2.1 Lamellar tearing normally occurs in susceptible material underneath the weld, in a direction generally parallel to the plate surface and often slightly outside the heat-affected zone. Lamellar tearing generally has a step-like appearance consisting of “terraces” (cracks running parallel to the plate surface) and “walls” (cracks which connect the individual terraces). The tearing may remain completely subsurface or appear at plate edges or at weld toes.

**X1.3 Inclusions**

X1.3.1 The step-like cracking characteristic of lamellar tearing is usually considered to result from small elongated nonmetallic inclusions that are normally present in the steel. Strains in the through-thickness direction can cause individual inclusions to fracture or decohere from the surrounding steel matrix, thus initiating a void. Further strain can cause the remaining metallic ligaments to shear or rupture, resulting in the step-like fracture appearance.

X1.3.2 A high or concentrated inclusion content in the steel produces planar regions of poor ductility parallel to the steel surface. On the other hand, a reduction in the magnitude and concentration of these inclusions to a low level tends to

preclude any easy fracture path along the low ductility inclusions and the steel exhibits improved ductility in a through-thickness direction.

X1.3.3 The extent of nonmetallic inclusions depends on the type of steel. In silicon semikilled or fully killed steels, these inclusions are primarily oxides (present as silicates) and sulfides (present as manganese sulfides). For aluminum-silicon killed steels, these inclusions are primarily sulfides (manganese sulfides). To improve the through-thickness ductility and thus the resistance of the steel to lamellar tearing, it is necessary to reduce the level of the nonmetallic inclusions. To provide a high resistance to lamellar tearing may require the use of special steel-making processes that can reduce the oxygen and sulfur contents in the steel to very low levels.

**X1.4 Steel Manufacturing Processes**

X1.4.1 Special steel-making processes are available for improving the through-thickness ductility. The more common processes, used singly or in combination, are: (1) low sulfur practices; (2) inclusion shape control; (3) electroslag or vacuum arc remelting; and (4) vacuum degassing. The steel-making processes are not all intended for the same purpose, but will improve the through-thickness ductility to various degrees depending on the process used.

**X1.5 Through-Thickness Ductility Requirements**

X1.5.1 Susceptibility to lamellar tearing depends on many factors (for example, restraint, welding conditions, etc.) and, consequently a specific through-thickness ductility requirement does not provide a guarantee against lamellar tearing. The most widely accepted method of measuring the material ductility factor of susceptibility to lamellar tearing is the reduction of area of a round tension test specimen oriented perpendicular to the rolled surface of a plate.

**X2. TESTING PARAMETERS AFFECTING REDUCTION OF AREA VALUES****X2.1 Variability of Through-Thickness Properties**

X2.1.1 Through-thickness tension test results, and in particular the reduction of area determination as provided for in this specification, are subject to substantially greater scatter than would normally be expected from standard tension tests of a plate in the longitudinal or transverse direction. This scatter of test results is due in part to the inherent variability of the distribution of the nonmetallic inclusions discussed in X1.3. For example, those nonmetallic inclusions that form during the solidification phase of the steelmaking process tend to occur with a higher frequency in the area of final solidification.

X2.1.2 Test specimen design may also have an effect on the test results. Some of these factors are discussed in X2.2.

Operator technique will also be a factor in increasing scatter, particularly in the measurement of the final diameter of the test specimen. Because of the effect of inclusions on the fracture process, the appearance of the final fracture may be quite different than the classical cup-cone fractures common to longitudinal and transverse tension testing. For those materials with approximately 20 % reduction of area, the final diameter measurement may require a substantial amount of judgment on the part of the test operator.

X2.1.3 In view of the potential variability of the through-thickness reduction of area test results, it is recognized that two tests per plate are not sufficient to fully characterize the through-thickness ductility of that plate. The number of tests

and test positions have not been established that would provide a good estimate of both the mean and the variability of through-thickness tensile reduction of values of a plate. Therefore, an average value requirement is not included in this specification. The intent of this specification is to qualify a plate according to the described testing procedures using only a minimum value requirement. The potential variability of the test results also increases the possibility that subsequent testing of a steel plate qualified according to this specification may produce results that do not meet the specified acceptance standard.

## **X2.2 Effects of Test Specimen Design**

X2.2.1 Two main factors considered in the selection of test specimen geometry were the diameter and the slenderness ratio. It is generally accepted that there is a diameter effect on reduction-of-area values such that a smaller diameter specimen generally yields a higher average reduction in area value. It is

also accepted that smaller diameter test specimens will tend to give greater variability to the resulting reduction in area values. Because these relationships between the test specimen diameter and the average and variability of the test result have not been satisfactorily quantified at this time, the same minimum requirement has been applied to all test specimen diameters.

X2.2.2 The slenderness ratio (reduced section length/reduced section diameter) is known to affect the reduction in area values when below a minimum value. This minimum value may be from 1.5 to 2.5, depending on the material. Below this minimum value, the reduction at the failure point in the reduced section is restrained by the larger cross section away from the reduced section. A minimum slenderness ratio of 2 was selected for the standard Type 2 specimen to allow a 0.500-in. [12.5-mm] diameter specimen to be used on a 1-in. [25-mm] plate. A minimum slenderness ratio of 2.5 was selected for the collar-button specimens (Types D, E, and F) to ensure that this effect is minimized for these test specimens.

*ASTM International takes no position respecting the validity of any patent rights asserted in connection with any item mentioned in this standard. Users of this standard are expressly advised that determination of the validity of any such patent rights, and the risk of infringement of such rights, are entirely their own responsibility.*

*This standard is subject to revision at any time by the responsible technical committee and must be reviewed every five years and if not revised, either reapproved or withdrawn. Your comments are invited either for revision of this standard or for additional standards and should be addressed to ASTM International Headquarters. Your comments will receive careful consideration at a meeting of the responsible technical committee, which you may attend. If you feel that your comments have not received a fair hearing you should make your views known to the ASTM Committee on Standards, at the address shown below.*

*This standard is copyrighted by ASTM International, 100 Barr Harbor Drive, PO Box C700, West Conshohocken, PA 19428-2959, United States. Individual reprints (single or multiple copies) of this standard may be obtained by contacting ASTM at the above address or at 610-832-9585 (phone), 610-832-9555 (fax), or [service@astm.org](mailto:service@astm.org) (e-mail); or through the ASTM website ([www.astm.org](http://www.astm.org)). Permission rights to photocopy the standard may also be secured from the Copyright Clearance Center, 222 Rosewood Drive, Danvers, MA 01923, Tel: (978) 646-2600; <http://www.copyright.com/>*